

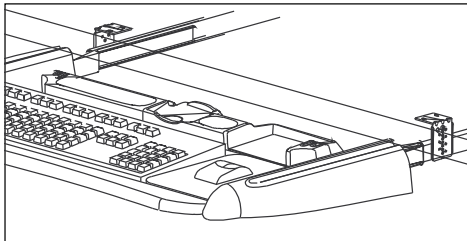

## CBERGO-TRAY300

**APPLICATIONS:** For metal or wood furniture in home office furniture and office workstation desktops. **This product is covered by U.S. (09/305353) and various foreign patents issued (ROC 74826) and/or pending.**

Deluxe Keyboard System



**Finish** Black powder-coated (CB) finish

**Unit Profile** Width: 29-19/32" [751.7mm]  
Depth: 19-13/16" [503.2mm]

**Slide Travel** For typing: 10-9/32" [261.1mm]  
Fully open: 15-9/32" [388.1mm]

**Tray Profile** Inside tray width: 25-1/2" [647.7mm]  
Inside tray depth: 8-19/32" [218.3mm]

**Mounting Space** Minimum 30" [762.0mm] Width

**Brackets** Variable height, Inboard/outboard

**Tilt Plate** Adjust at -7°, -3.5°, and neutral (flat)

**Detents** Closed, typing, and full open positions

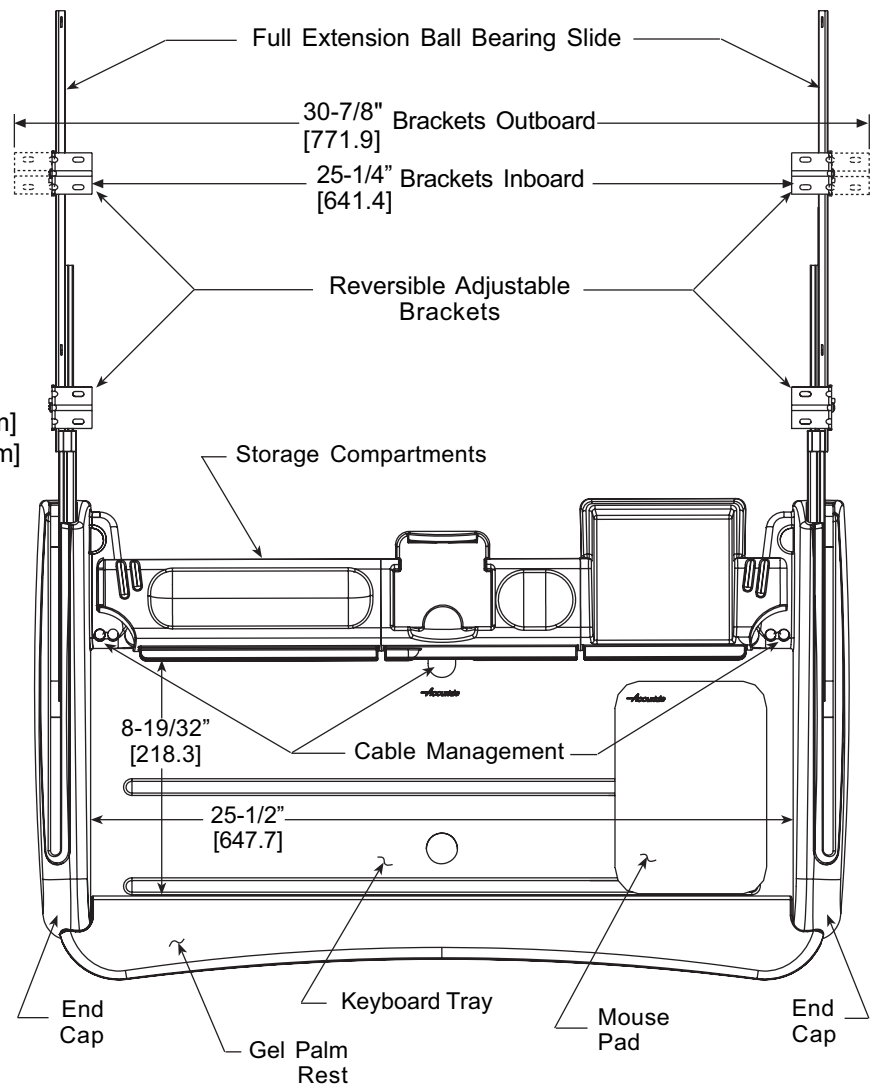

### Features

- Ergonomic design
- Slides fully concealed from view
- All rough edges and pinch points eliminated
- No transfer of grease
- Variable height mounting brackets
- Rubber bumpers prevent tilt plate rattling
- Removable full-width gel palm rest
- Large tray width provides unhandled mouse surface
- Brackets mounted inboard or outboard provide installation flexibility
- Accommodates any size keyboard by removing palm rest
- Intermediate detent allows user closer proximity to work surface
- Tilt plate provides added adjustability at -7°, -3.5°, and neutral (flat)
- Rear storage compartments keep office supplies within reach and out of sight
- Slides fully extend to provide complete access to rear storage compartments
- Cable management fixtures incorporated in rear of tray

Before you begin, unpack the new keyboard assembly and inspect for damage. If there is any damage or the product does not operate properly, contact your Accuride Distributor for further details.

**NOTE:**

This keyboard assembly is designed and intended to support computer keyboards and mice only. The mounting screws included are suitable for mounting into either wood materials or sheet metal, when the proper pilot hole is provided. All eight mounting screws should be fully tightened to mate the bracket to the mounting surface.

**CAUTION:** Always protect your eyes and wear safety goggles or glasses during installation.

**Required Tools**

- #2 Phillips Screwdriver (Minimum 6" long shank)
- Drill (6" long screwdriver bit required for inboard mounting)
- Scratch Awl
- 1/16" Drill Bit

**Suggested Mounting Surface**

- Use sturdiest material possible. Minimum 3/4" thick composite (MDF, plywood, or particle board) is recommended.

**Installation Instructions**

**Step 1**

- Determine the preferred mounting location of the keyboard assembly.
- For flush mounting, fold the installation template on the dotted line and align the front edge (as noted) to the edge of the work surface. Otherwise, adjust the installation template to fit the desired location.
- Tape installation template in place.

**Step 2**

- The mounting brackets can be mounted "Inboard" or "Outboard". Determine the orientation of the mounting brackets for your unit. See Figure 1.

**Step 3**

- Punch eight pilot holes with a scratch awl and drill eight 1/16" diameter starter holes in the designated installation template locations for selected mounting style (inboard or outboard).

**NOTE:** Use caution while drilling pilot holes to prevent full penetration of desktop.

**Step 4**

- Remove the installation template.

**Step 5**

- The unit is shipped with the mounting brackets installed in the lowest inboard setting. Remove and adjust as required.

Figure 1

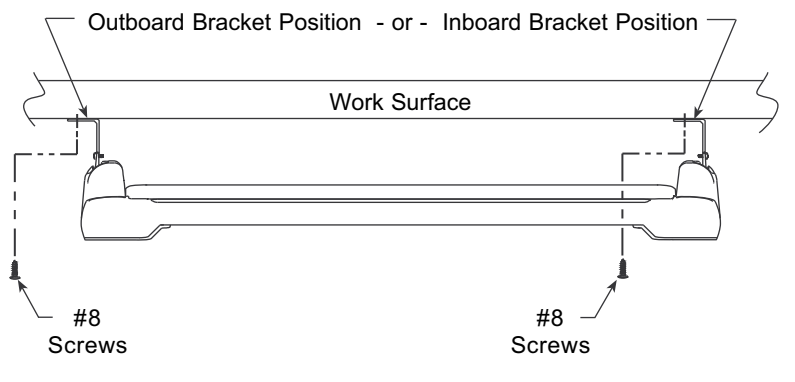

Figure 2

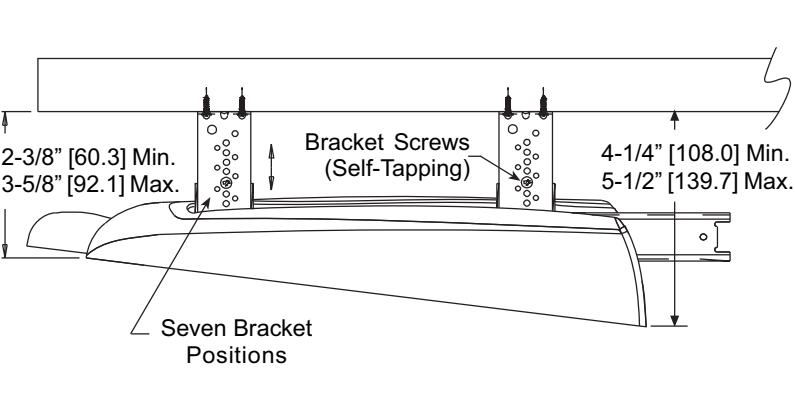

Figure 3

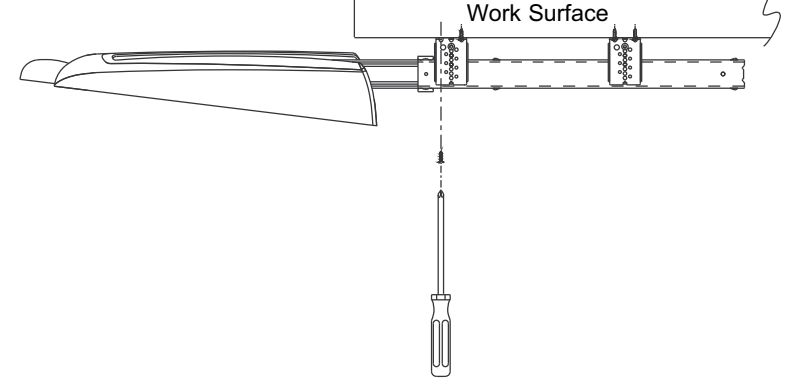
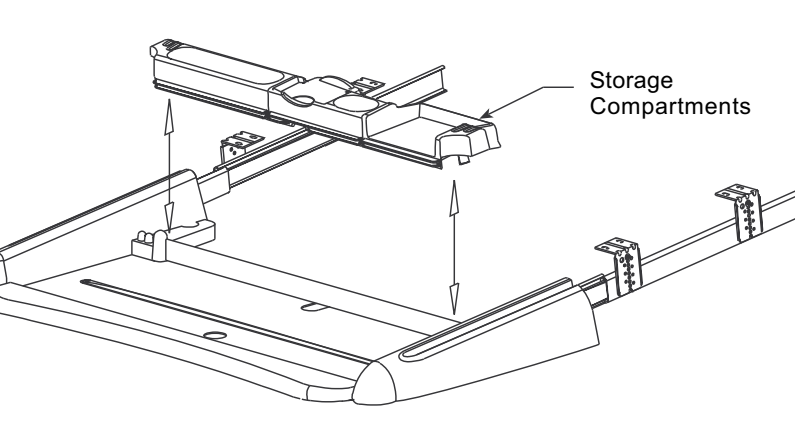

Figure 4



- Using a Phillips screwdriver, remove the bracket screws. See Figure 2. Position the brackets to accommodate the preferred height and mounting orientation.
- Ensure that each bracket is adjusted to the same vertical setting.
- To maximize knee space, adjust brackets just enough to clear keyboard during travel.
- The self-tapping bracket screws can be installed from either direction. When repositioning brackets, make sure to reinstall the same screws.

### Step 6

- While holding the unit in place, fasten the two rear brackets to the work surface with a Phillips screwdriver (start with one screw per bracket). Each bracket will use two #8 X 5/8" screws.
- While holding the unit in place, extend the keyboard drawer to the fully open position. See Figure 3. Fasten the two front brackets.

**NOTE: Fully tighten the screws on one side. After all the brackets have been fastened, cycle the drawer a few times to be certain the slides have self-adjusted to a parallel movement and are moving freely.**

### Step 7

- After the unit has been cycled a few times, the slide alignment has self-adjusted. Close keyboard slightly, tighten the rear bracket screws on the other side, and install the remaining screws.
- Extend tray fully and install the remaining screws in the front brackets.
- If the brackets are not properly aligned, a slight dragging will be evident.

### Step 8

- Install storage compartment into the drawer unit and snap into place. See Figure 4.

### Step 9

- Install tilt plate and set desired angle to maximize proper ergonomic positioning. See Figure 5.

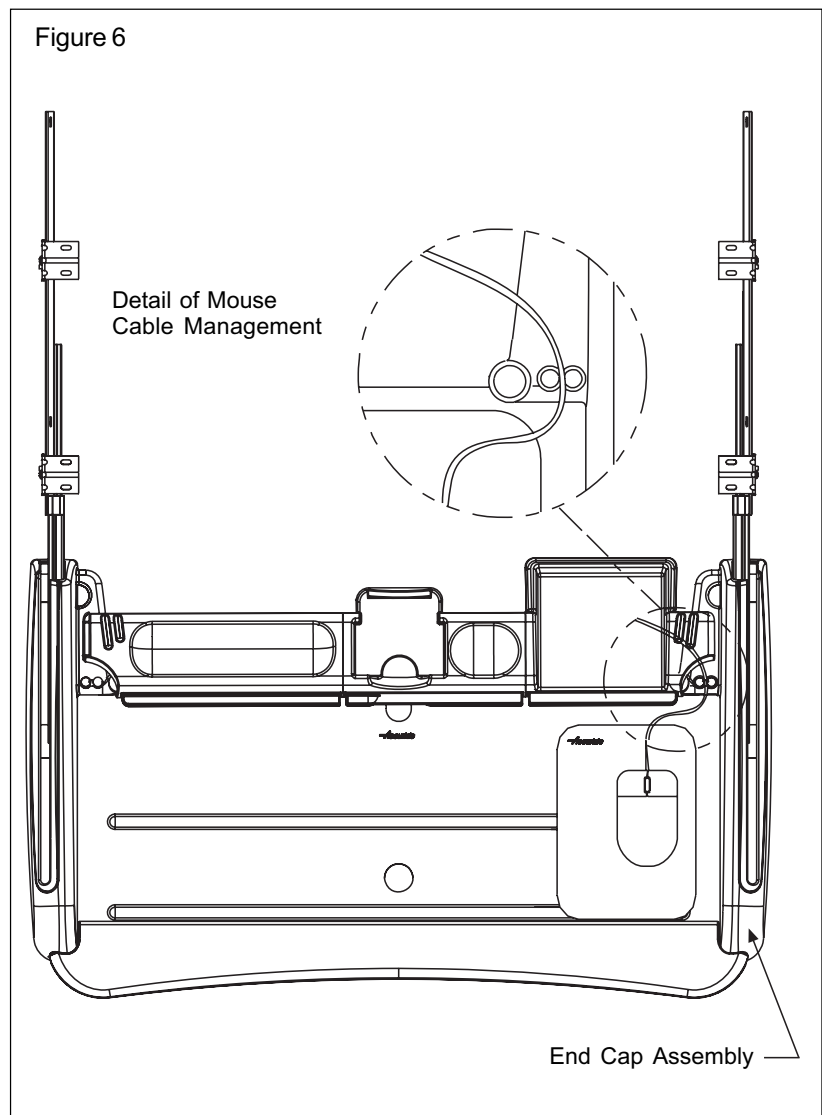
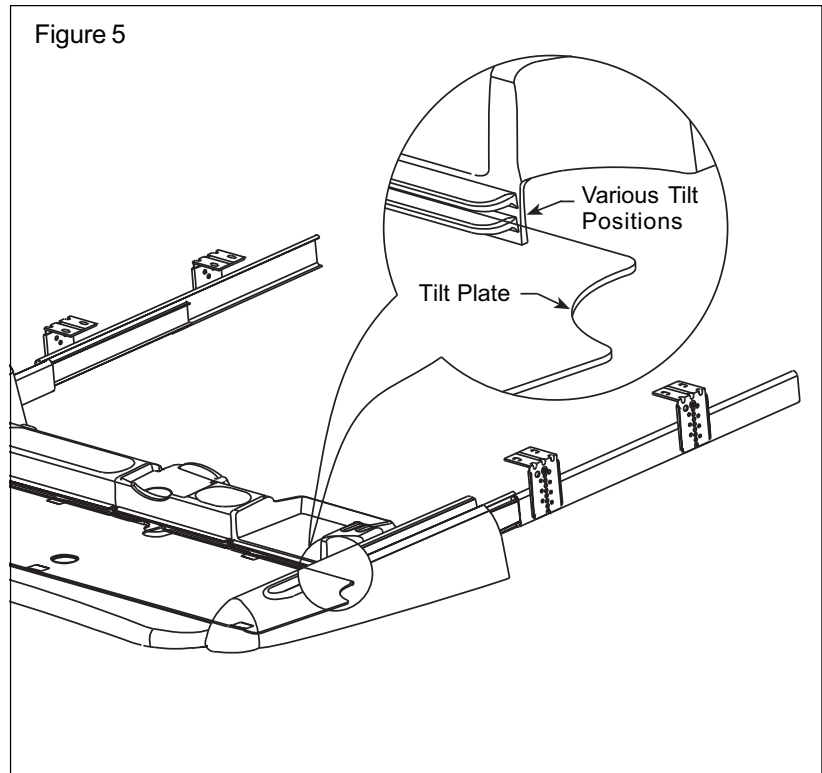

## Cable Management

- Locations for mouse cable management can be found at either the rear left hand or rear right hand side of the tray at the rear of the end cap assembly. See Figure 6.
- The mouse cable is held in place by positioning it between the two small pins and pressing into place.
- If a free-moving mouse cable is preferred, position cable between the large and small pins.
- An oval cut-out located in the center of the keyboard tray is provided for keyboard cable management.

## Ordering Procedure

4

Complete your order for Accuride Model CBERGO-TRAY300 by specifying the following:

Total Keyboards Required 5 Each  
Part Number CBERGO-TRAY300

## Packaging

Individually packaged in special carton with slides attached to keyboard. Includes hardware mounting kit part number 4180-0395-XE which includes:

8 each 2410-3241-CE #8-17 X 5/8" self-tapping screws

## Specifications

Slide members: Cold rolled steel

Ball retainers: Cold rolled steel

Ball bearings: Carburized steel

Keyboard tray: Cold rolled steel

Tilt tray: Plastic

Palm rest: Gel

Mouse pad: Foam

End caps: ABS, molded plastic

Storage Compartments: ABS, molded plastic

**Note:** Specifications, materials, prices, terms, and delivery are subject to change without notice.

# Accuride

ACCURIDE INTERNATIONAL INC.

12311 Shoemaker Avenue  
Santa Fe Springs, CA 90670

TEL (562) 903-0200

FAX (562) 903-0208

www accuride.com

Manufacturing, Engineering, and Sales

United States • Germany • Japan • Mexico • United Kingdom

Copyright © 2002 Accuride International Inc. Printed in U.S.A. 3700-9428-MK077-R7-0403