

www.ergotron.com
 USA 1-800-888-8458
 Europe +31 (0)33-45 45 600
 China 86-769-86018920

ASSEMBLY INSTRUCTIONS
Instrucciones de instalación
Notice d'assemblage
Montageanleitungen
Installatie instructies
Manuali d'Istruzione
 取扱説明書
 安装说明
 설치 안내

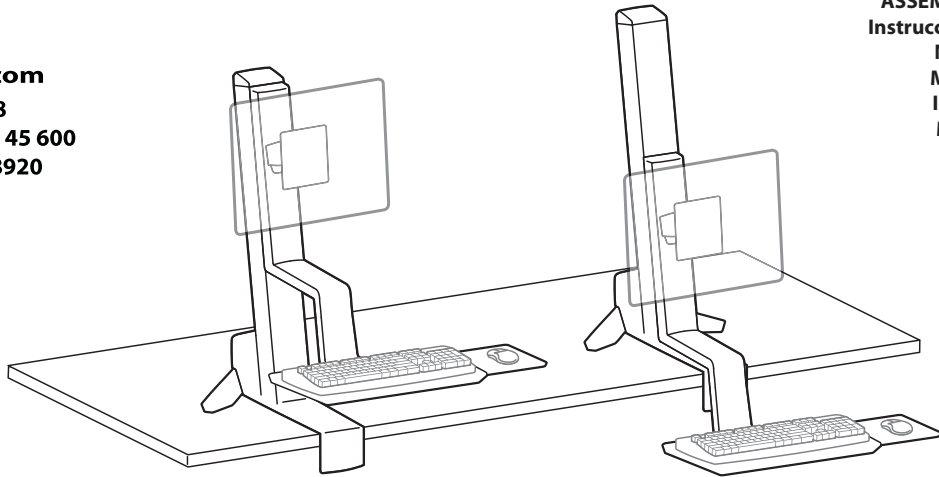

	A	B
1	1x	3x M5 x 14mm
2		1x M5 x 8mm
3		4x M5 x 18mm
4	1x	1x M3 x 6mm
		4x M4 x 10mm
5	1x	4x M4 x 10mm
6	1x	
7	1x	3x 3x
8	2x	1x 4mm 1x 3mm
9	1x	4x M5 x 8mm

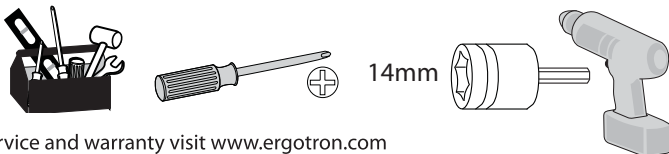
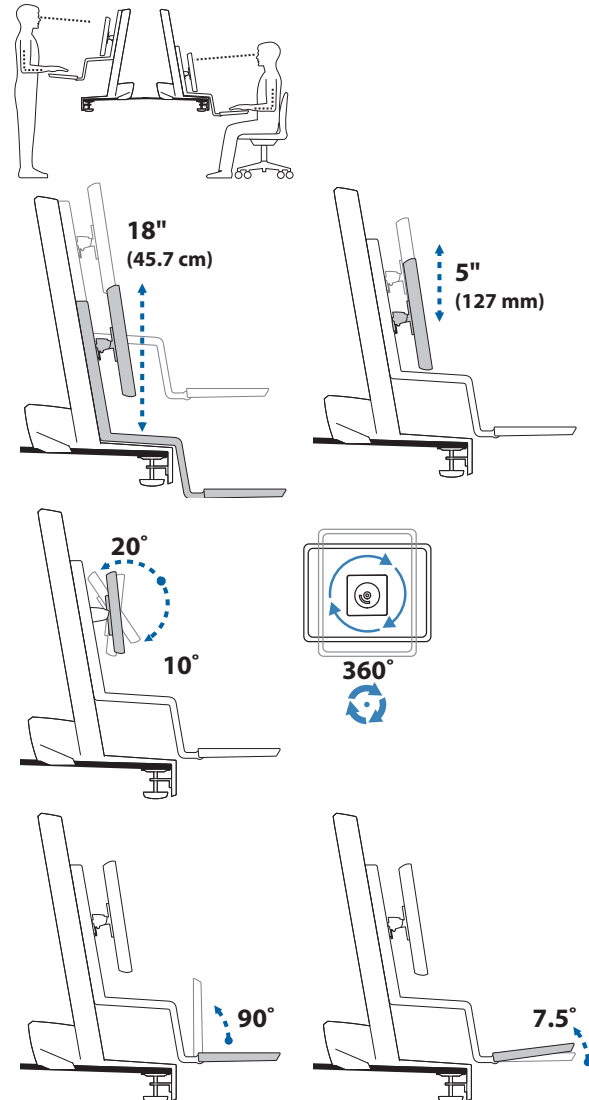
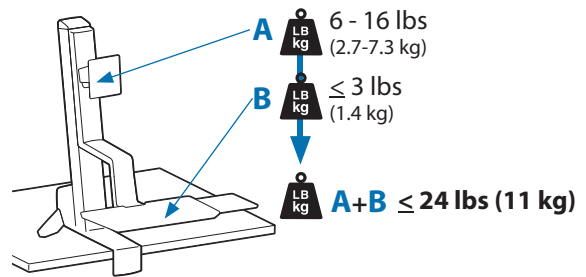

For service and warranty visit www.ergotron.com
 Para recibir servicio y garantía visite www.ergotron.com
 Pour un entretien et garantie consultez la page www.ergotron.com
 Informationen zur Service und Gewährleistung finden Sie unter www.ergotron.com
 Voor service en garantie gaat u naar www.ergotron.com
 Para recibir servicio y garantía visite www.ergotron.com
 服务和保修请访问 www.ergotron.com

1

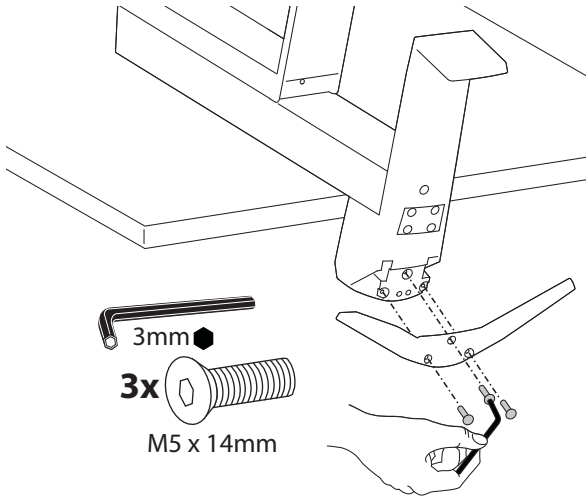

2

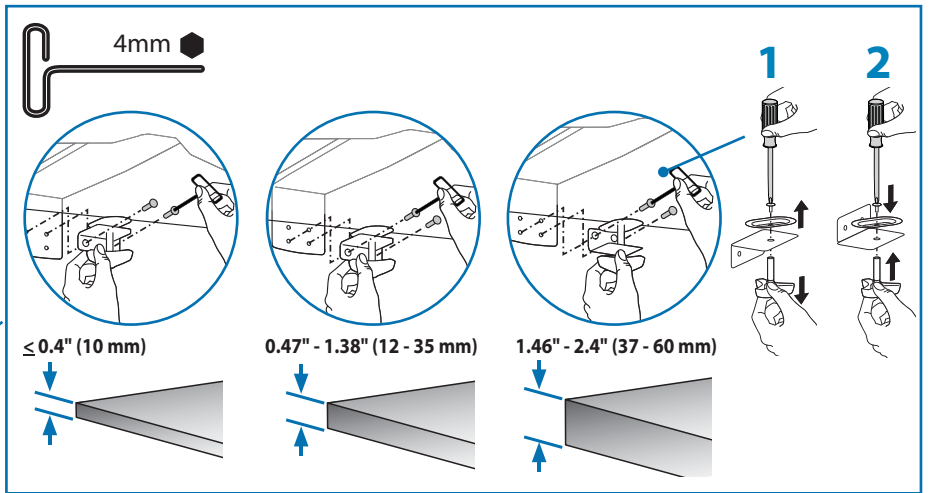
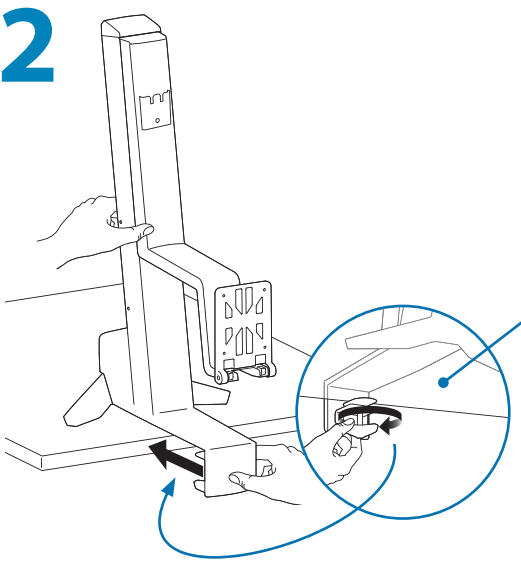

3

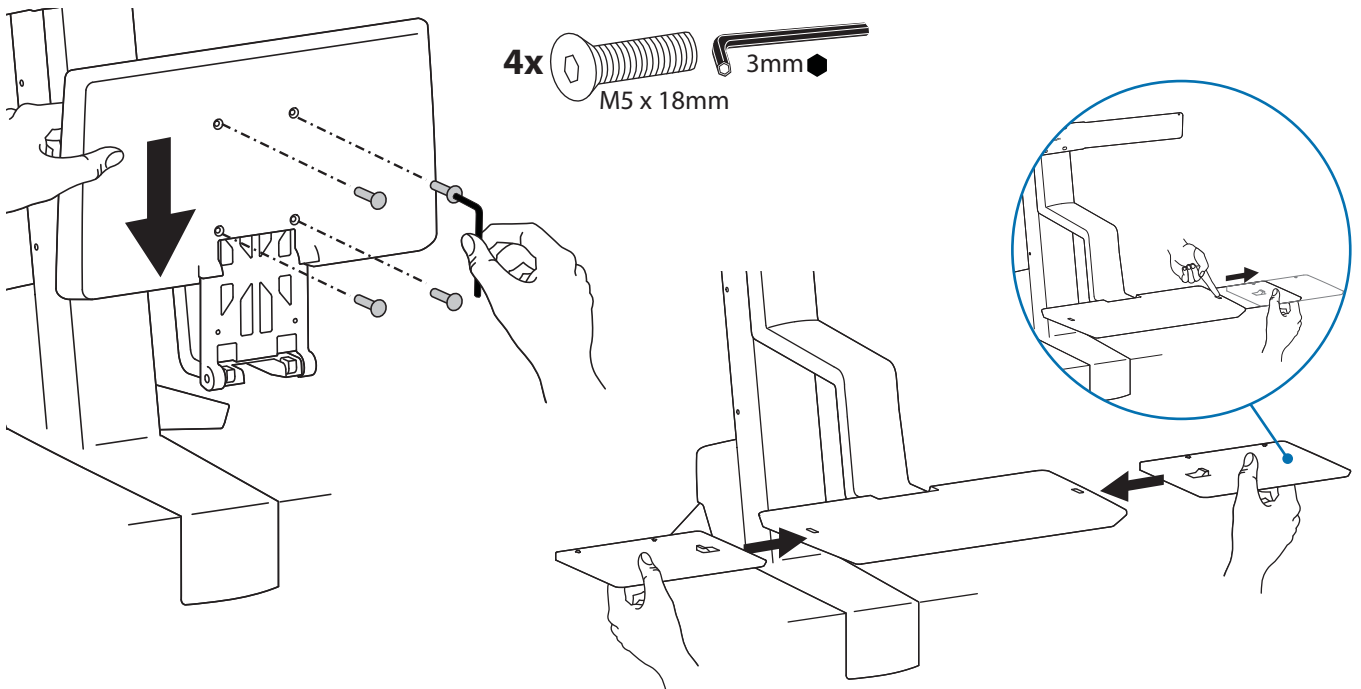

4

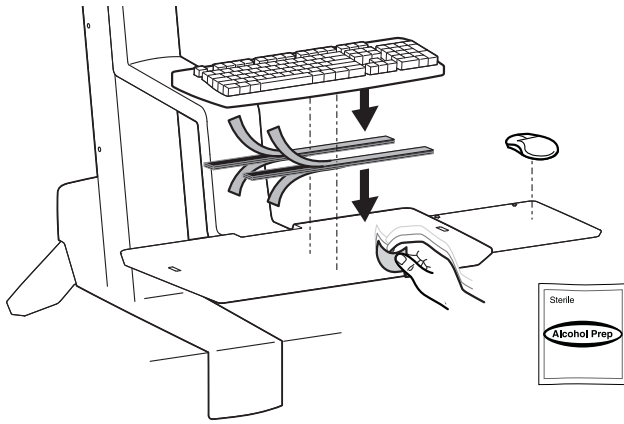

5

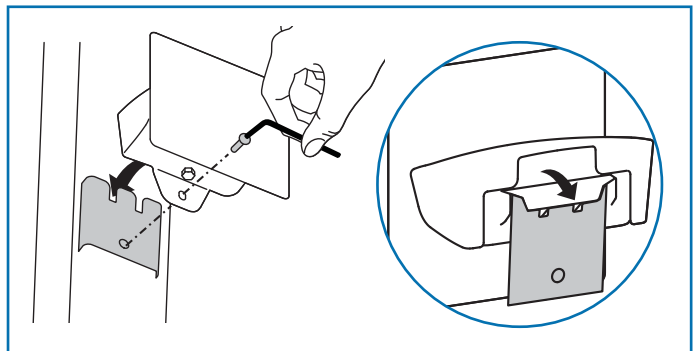
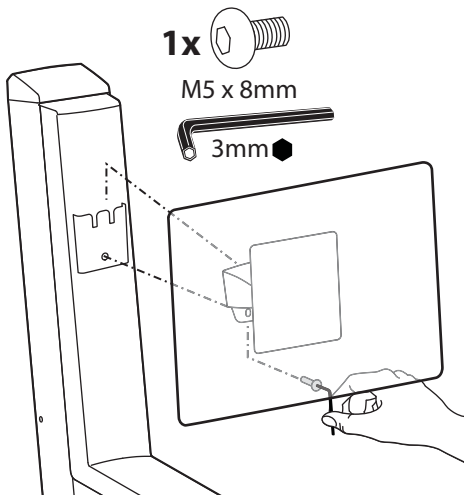
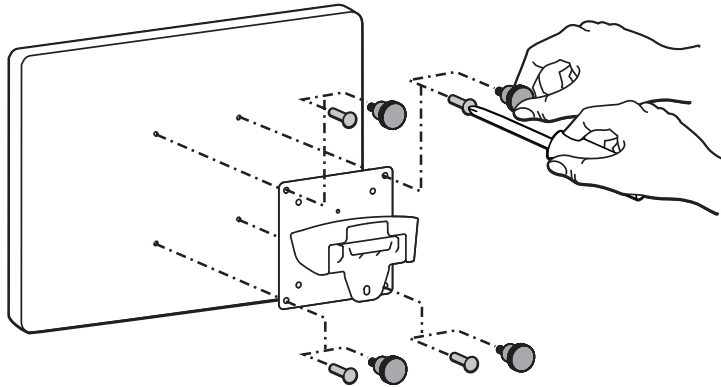
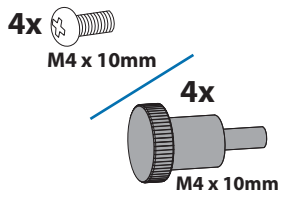
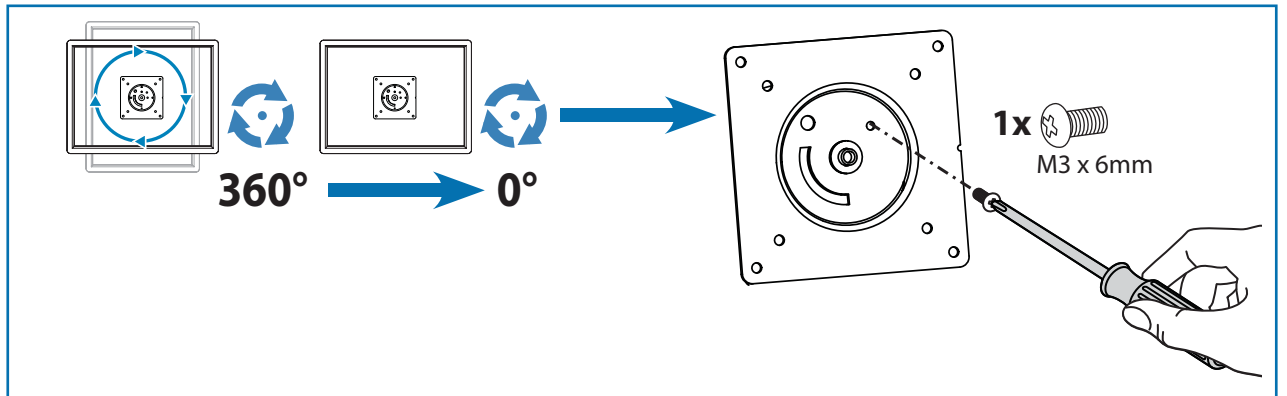

4

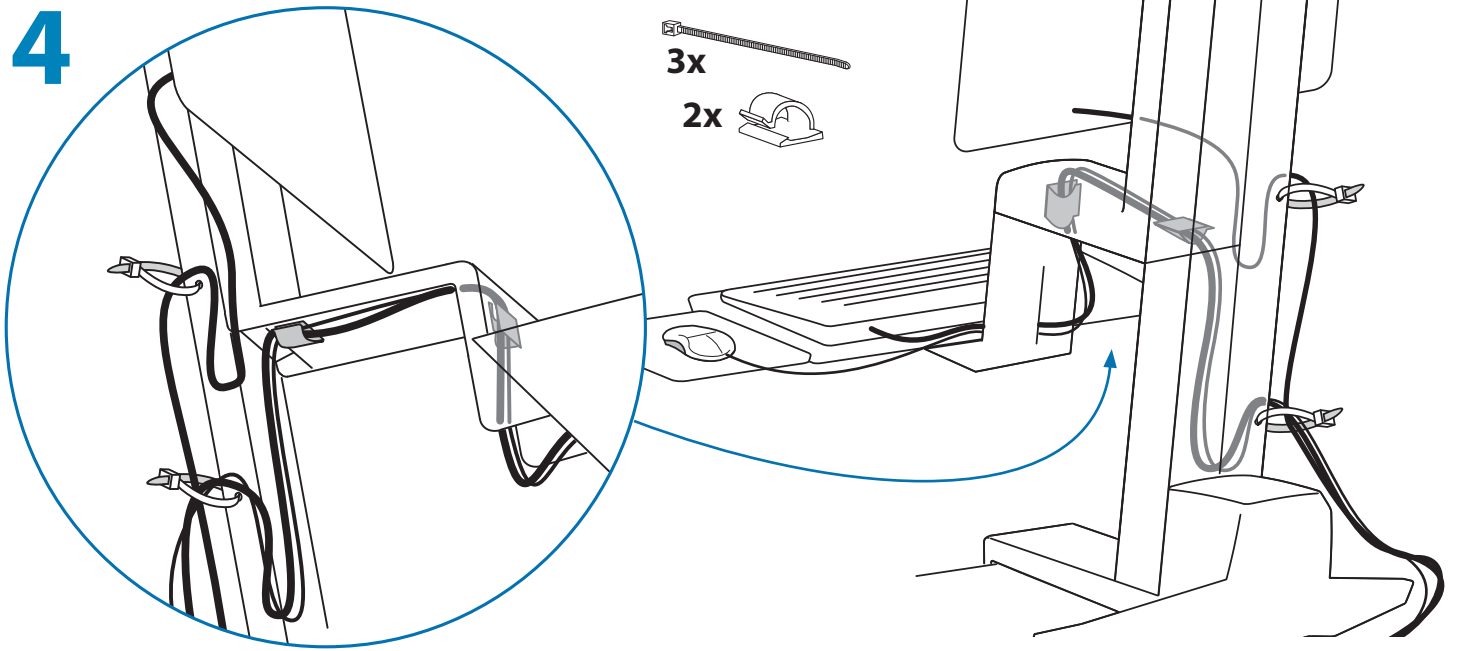

Adjustment · Ajuste · Réglage · Einstellung · Instellen · Regolazione · 調整 · 调节 · 조절

Follow these instructions to tighten or loosen tension.
 Siga estas instrucciones para ajustar o aflojar la tensión.
 Suivez ces instructions pour desserrer ou resserrer la tension.
 Befolgen Sie diese Anleitung, um die Spannung zu lockern oder zu verstärken.
 Volg deze instructies om de spanning te vergroten of verkleinen.
 Seguire queste istruzioni per aumentare o ridurre la tensione di bloccaggio.
 圧力を増減するには次の手順に従います。
 遵照这些说明拧紧或拧松。
 다음 지침에 따라 장력을 높이거나 줄이십시오.

! WARNING



Impact Hazard!

Moving Parts can Crush and Cut.

Raise to the full up position before removing equipment.

Always adjust the lift tension to accommodate applied load.

DO NOT add weight below minimum or above maximum weight capacities.

Failure to heed this warning may result in serious personal injury or property damage.

1

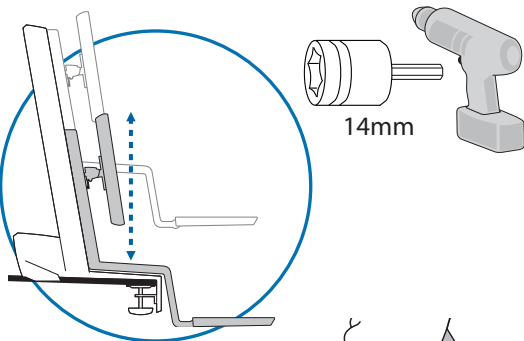

WARNING! Stored Energy Hazard: The arm mechanism is under tension and will move up rapidly, on its own, as soon as attached equipment is removed. For this reason, **DO NOT** remove equipment unless the arm has been moved to the highest position! Failure to follow this instruction may result in serious personal injury and/or equipment damage!

ADVERTENCIA: Riesgo de energía almacenada: El mecanismo del brazo está bajo tensión y se moverá rápidamente hacia arriba, por sí mismo, tan pronto como se retire el equipo acoplado. Por ello, **NO** retire el equipo a menos que esté colocado en su posición más elevada. El incumplimiento de esta instrucción puede provocar lesiones personales graves y dañar el equipo.

AVERTISSEMENT! Risque d'énergie accumulée : Le mécanisme du bras est sous tension et se lèvera rapidement, tout seul, dès que le matériel est retiré. Pour cette raison, **NE PAS** retirer votre matériel à moins que le bras n'ait été mis à la position la plus élevée ! Risque de blessure corporelle et/ou d'endommagement du matériel en cas de non-respect de cette instruction !

WAARSCHUWING! Rischio da energia immagazzinata: il meccanismo del braccio è sotto tensione e si muove rapidamente da sé non appena si toglie l'apparecchiatura a cui è collegato. Per questo motivo, **NON** rimuovere l'apparecchio a meno che il braccio non sia stata portato sulla posizione più alta. La mancata osservanza di questa precauzione può causare infortuni gravi e/o danni all'apparecchiatura.

WARNING! Gefährdung durch gespeicherte Energie: Der Arm-Mechanismus der Arbeitsfläche steht unter Spannung und bewegt sich von allein und schnell nach oben, sobald das befestigte Gerät abgenommen wird. Entfernen Sie aus diesem Grund die Geräte nur, wenn sich der Arm auf der höchsten Position befindet! Eine Missachtung dieser Anweisung kann zu ernsthaften Verletzungen und/oder Beschädigungen am Gerät führen.

AVVERTENZA! Gevaar door opgeslagen energie: het hefmechanisme van het werkoppervlak staat onder spanning en verplaatst zich zelfstandig snel omhoog wanneer de bevestigde apparatuur wordt verwijderd. Verwijder apparatuur daarom **ALLEEN** nadat de arm in de hoogste stand is gezet! Als u deze instructie niet opvolgt, kan dit tot ernstig persoonlijk letsel en/of beschadiging van de apparatuur leiden!

警告: 蓄積エネルギーの危険: アームメカニズムには張力が作用しており、付属機器を取り外すと自動的に素早く上に跳ね上がります。そのため、付属機器を取り外す前にアームが一番上の位置に移動してください。この指示を無視すると、重大な人体への傷害や機器の損傷を招く恐れがあります。

警告! 储能危险: 支臂机构处于受力状态, 在拆除所安装的设备后会自行快速上升。因此, 在将支臂移到最高位置之前, 不要拆除设备! 不遵守本规定可能导致严重的人身伤害和/或设备损坏!

경고! 저장된 에너지 위험: 팔 메커니즘은 장력을 받으며 부착한 장비를 제거하면 곧바로 빠른 속도로 위로 튕겨 오릅니다. 따라서 팔이 가장 높은 위치로 이동해 있지 않은 상태로는 장비를 제거하지 마십시오! 이 지침을 따르지 않으면 심각한 부상을 입거나 장비가 손상될 수 있습니다!

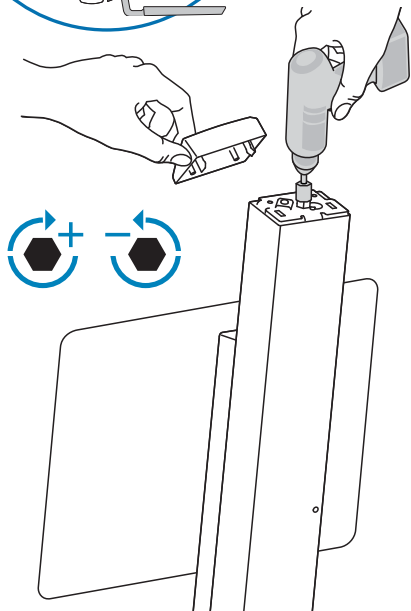

2

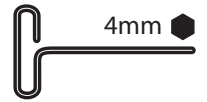
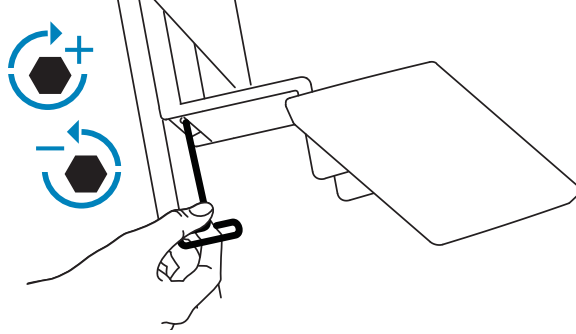
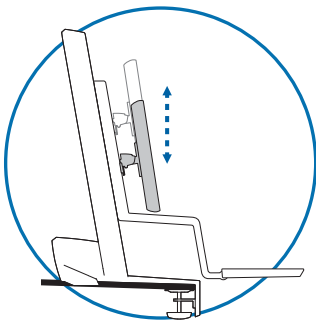

3

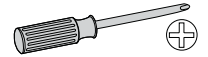
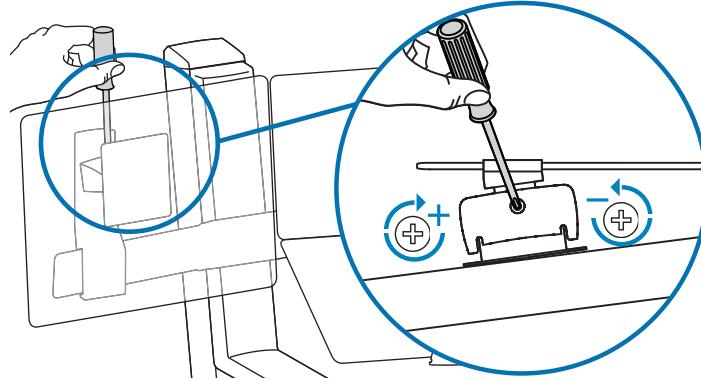
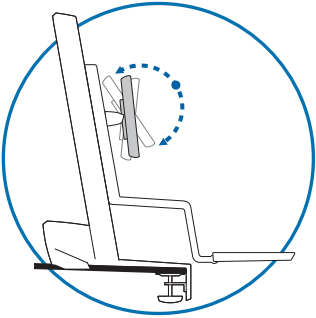

4

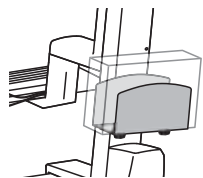
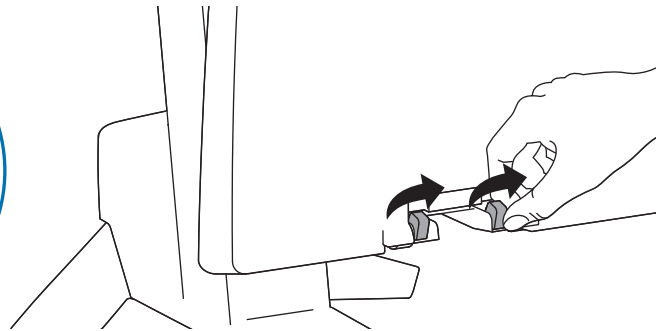
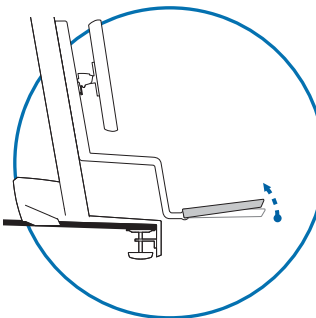

How to attach optional CPU holder ordered separately

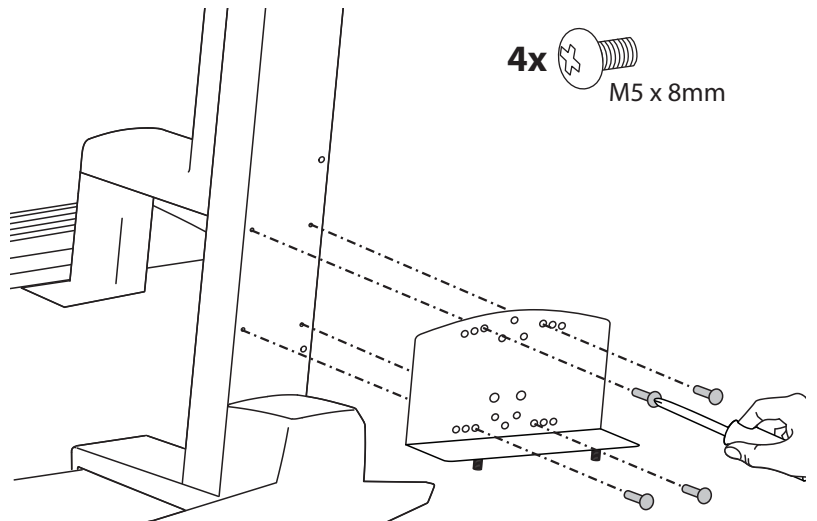

4x  M5 x 8mm



© 2010 Ergotron, Inc.
All rights reserved.

While Ergotron, Inc. makes every effort to provide accurate and complete information on the installation and use of its products, it will not be held liable for any editorial errors or omissions (including those made in the process of translation from English to another language), or for incidental, special or consequential damages of any nature resulting from furnishing this instruction and performance of equipment in connection with this instruction. Ergotron, Inc. reserves the right to make changes in the product design and/or product documentation without notification to its users. For the most current product information, or to know if this document is available in languages other than those herein, please contact Ergotron. No part of this publication may be reproduced, stored in a retrieval system, or transmitted in any form or by any means, electronic, mechanical, photocopying, recording or otherwise without the prior written consent of Ergotron, Inc., 1181 Trapp Road, Eagan, Minnesota, 55121, USA Patents Pending and Patented U.S. & Foreign. Ergotron is a registered trademark of Ergotron, Inc.

Americas Sales and
Corporate Headquarters

St. Paul, MN USA
(800) 888-8458
+1-651-681-7600
www.ergotron.com
sales@ergotron.com

EMEA Sales

Amersfoort, The Netherlands
+31 33 45 45 600
www.ergotron.com
info.eu@ergotron.com

APAC Sales

Tokyo, Japan
www.ergotron.com
apaccustomerservice@ergotron.com

Worldwide OEM Sales

www.ergotron.com
info.oem@ergotron.com