



WorkFit-D

ENGLISH

For service and warranty visit www.ergotron.com/warranty
Si desea información de servicio y garantía, visite www.ergotron.com/warranty
Pour toute question concernant la garantie ou le service client, consultez www.ergotron.com/warranty
Weitere Informationen zu Service und Gewährleistung erhalten Sie unter www.ergotron.com/warranty
Ga voor service en garantie naar www.ergotron.com/warranty
Per assistenza e la garanzia visitare www.ergotron.com/warranty
Gå in på www.ergotron.com/warranty för service och garanti
サービスおよび保証については、www.ergotron.com/warranty をご覧ください。
有关服务和保修，请访问 www.ergotron.com/warranty



www.ergotron.com



USA 1-800-888-8458

Europe +31 (0)33-45 45 600

China 400-120-3051

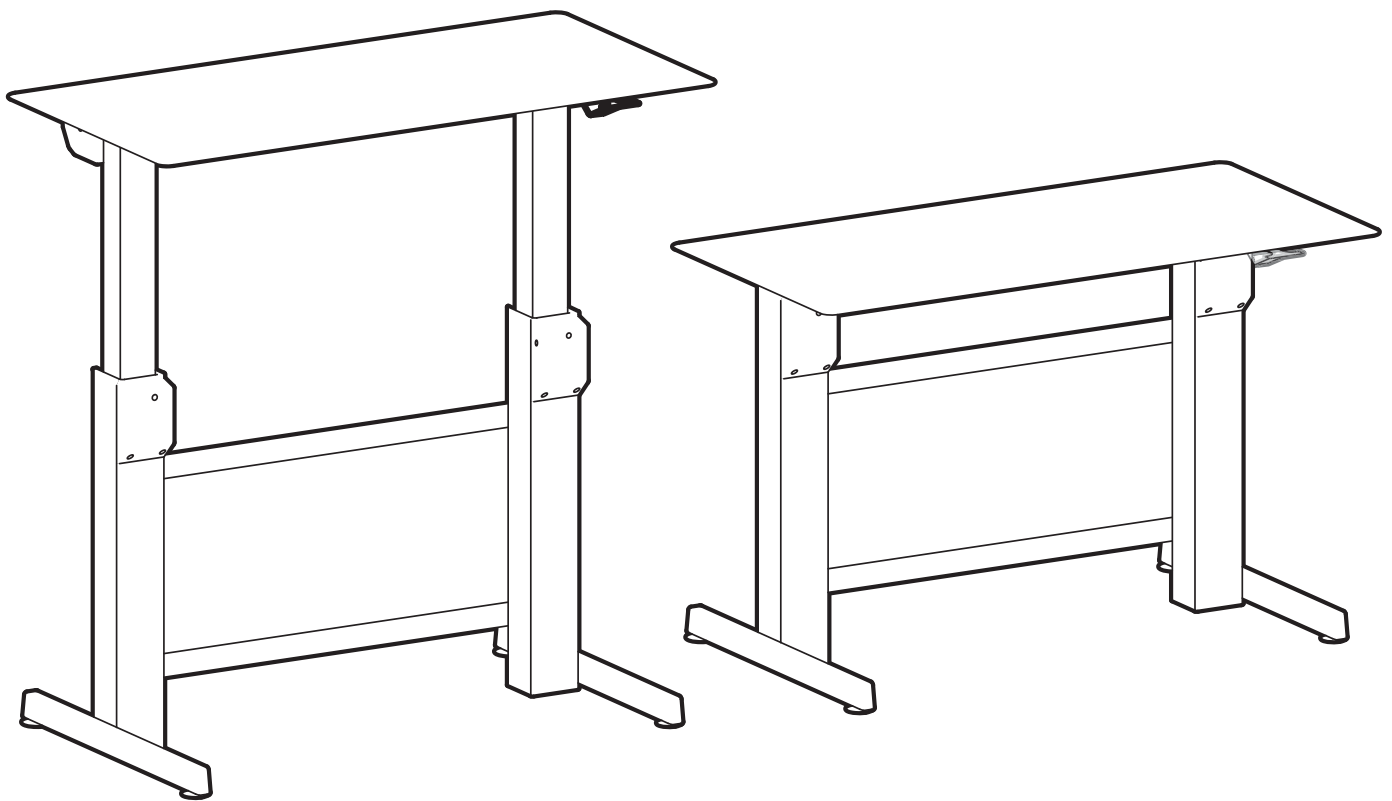

≤ 65 lbs. (29.5 kg)

Max weight 65 lbs – 29.5 kg





CAUTION: DO NOT EXCEED MAXIMUM LISTED WEIGHT CAPACITY. SERIOUS INJURY OR PROPERTY DAMAGE MAY OCCUR!



Reduce.Reuse.Recycle



Hazard Symbols Review

These symbols alert users of a safety condition that demands attention. All users should be able to recognize and understand the significance of the following Safety Hazards if encountered on the product or within the documentation. Children who are not able to recognize and respond appropriately to Safety Alerts should not use this product without adult supervision!

Symbol	Signal Word	Level of Hazard
	NOTE	A NOTE indicates important information that helps you make better use of this product.
	CAUTION	A CAUTION indicates either potential damage to hardware or loss of data and tells you how to avoid the problem.
	WARNING	A WARNING indicates either potential for property damage, personal injury, or death.
	ELECTRICAL	An Electrical indicates an impending electrical hazard which, if not avoided, may result in personal injury, fire and/or death.

Safety

 **WARNING**
IMPACT HAZARD

Moving Parts Can Crush And Cut

Minimize Lift Strength BEFORE:
 - Removing Mounted Equipment
and
Insert 4 Stop Screws BEFORE:
 - Shipping or Storing (i.e. when Desk is not upright).

To Minimize Lift Strength
 Refer to installation manual for instructions on how to minimize lift strength.

To Insert 4 Stop Screws
 Refer to installation manual for instructions on installing stop screws.

Failure to heed this warning may result in serious personal injury or property damage!

For More information and instructions visit www.ergotron.com or contact Ergotron Customer Care at **1-800-888-8458**.
826-901-00



Important! You will need to adjust this product after installation is complete. Make sure all your equipment is properly installed on the product before attempting adjustments. This product should move smoothly and easily through the full range of motion and stay where you set it. If movements are too easy or difficult or if product does not stay in desired positions, follow the adjustment instructions to create smooth and easy movements. Depending on your product and the adjustment, it may take many turns to notice a difference. Any time equipment is added or removed from this product, resulting in a change in the weight of the mounted load, you should repeat these adjustment steps to ensure safe and optimum operation.



WARNING! Stop screws are pre-installed in this product to secure it in the compressed position during shipping and installation. **DO NOT REMOVE THESE SCREWS UNTIL INSTRUCTED TO DO SO IN THESE INSTRUCTIONS.** Make sure these screws are in place before starting installation. Failure to follow these instructions may cause lift engine to expand rapidly and may result in equipment damage and or personal injury. If any of the 4 stop screws are not installed in these locations, contact customer care before continuing with installation.

IMPORTANT!

Save these stop screws and instructions. Install stop screws when shipping or storing this product. Failure to follow these instructions may cause lift engine to expand rapidly and may result in equipment damage and or personal injury.

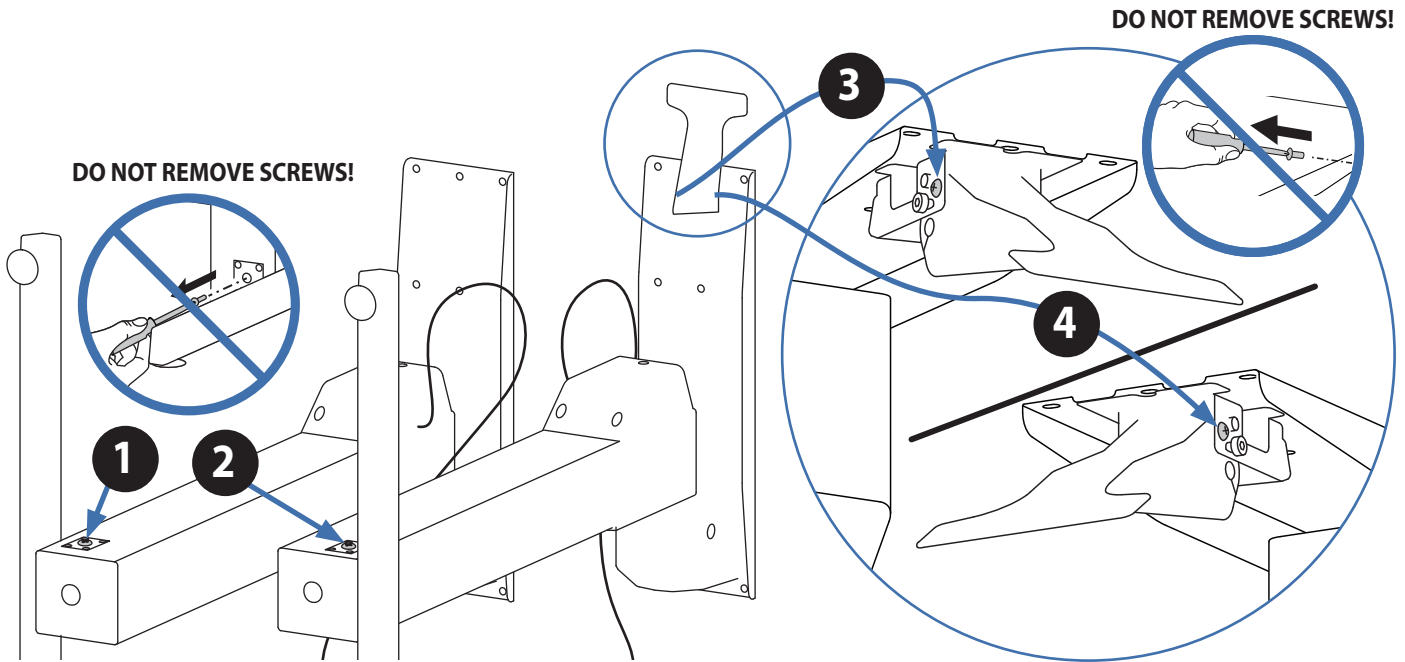

! WARNING

Keep Brake Cables Away from Sync Rod and Crossbars During Installation!

Failure to keep the brake cables away from sync rod and crossbars may restrict lift motion and may cause equipment damage or personal injury! Refer to instruction manual for more information.

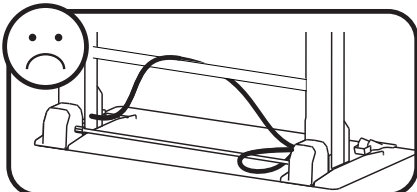
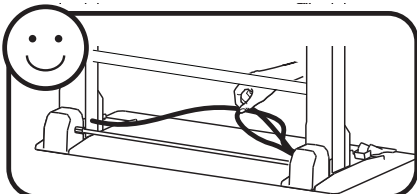

WARNING! TIPPING HAZARD!

When mounting accessories to the WorkFit-D, they must stay within the foot print. Do not mount accessories past the front and rear worksurface! Failure to follow this warning may result in equipment damage and or personal injury.

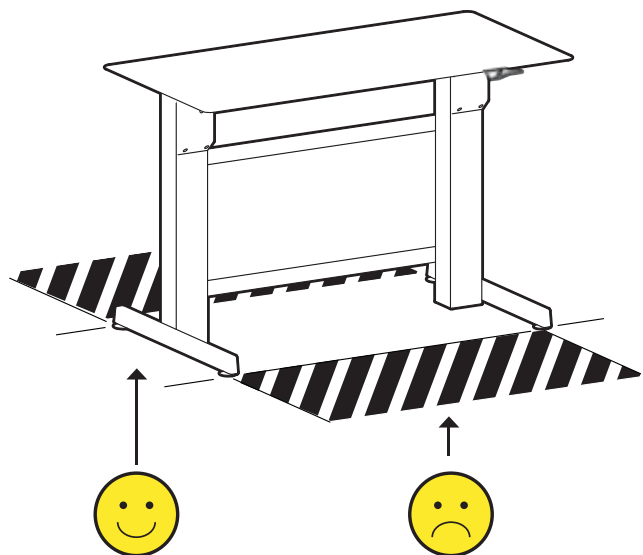

Components

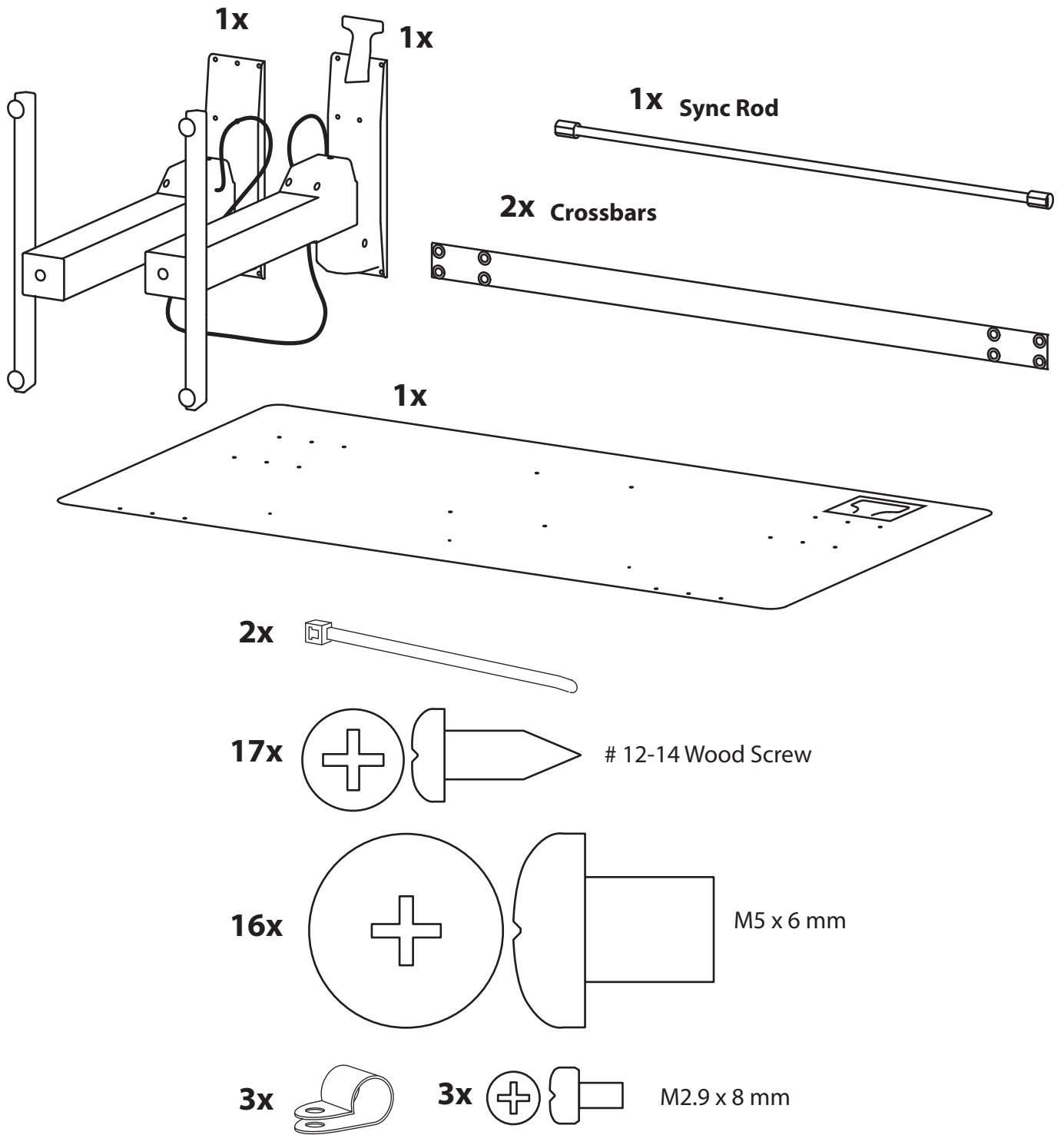

Tools Needed

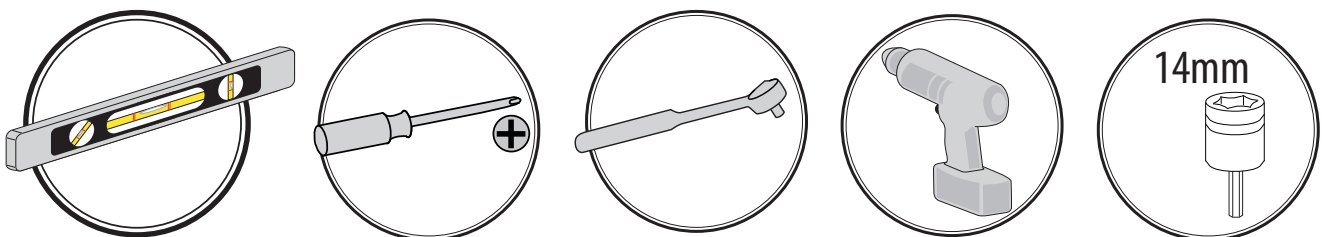

Set-up Steps

1 Place the worksurface on a clean floor with the top side facing down.

Carefully position the leg with the hand brake on the right end of the worksurface. Place the other leg on the left end.

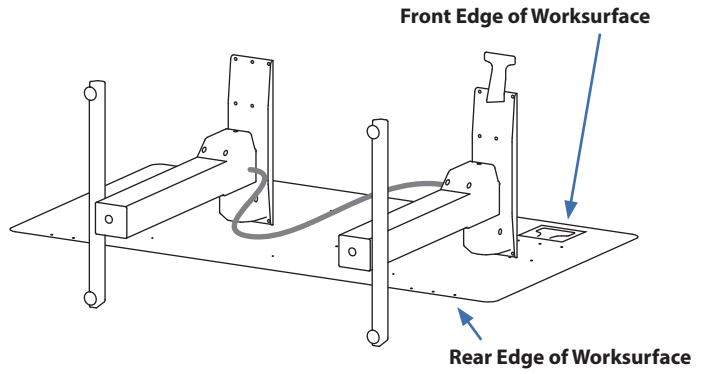

NOTE: The brake cable is attached to both legs. Take care when removing the legs from the packaging to avoid damaging or pulling the brake cable from the legs.

2 Set the right leg (with hand brake) upright on the worksurface.

Partially insert 3 of the provided #12-14 wood screws at the rear of the leg, 3 near the middle of the leg and 2 at the front of the leg.

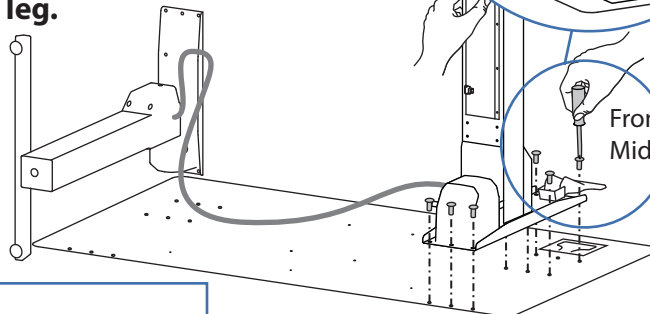

Front = 2 screws
Middle = 3 screws

Rear = 3 screws

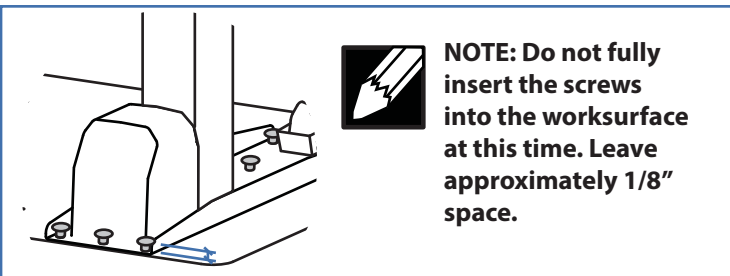

NOTE: Do not fully insert the screws into the worksurface at this time. Leave approximately 1/8" space.

3 Attach one end of the sync rod to the right leg as illustrated. Make sure the brake cables don't loop around the sync rod. See Warning, right.

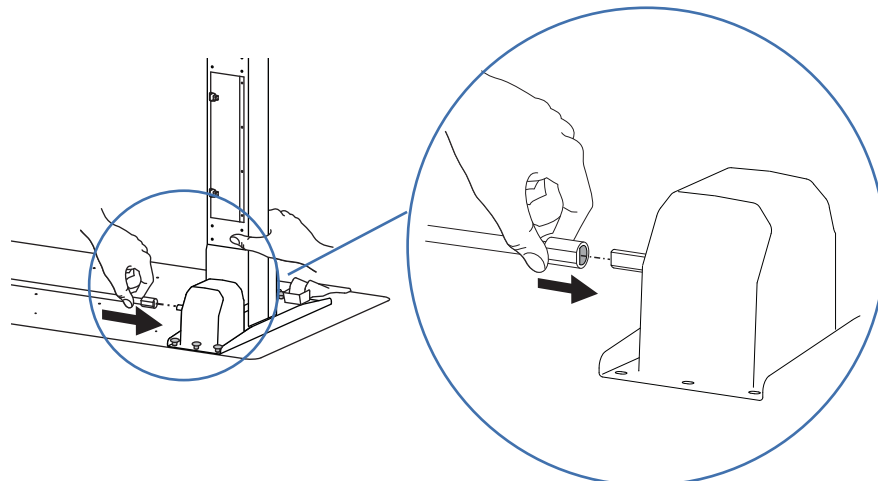

⚠ WARNING

Keep Brake Cables Away from Sync Rod and Crossbars During Installation!

Failure to keep the brake cables away from sync rod and crossbars may restrict lift motion and may cause equipment damage or personal injury! Refer to instruction manual for more information.

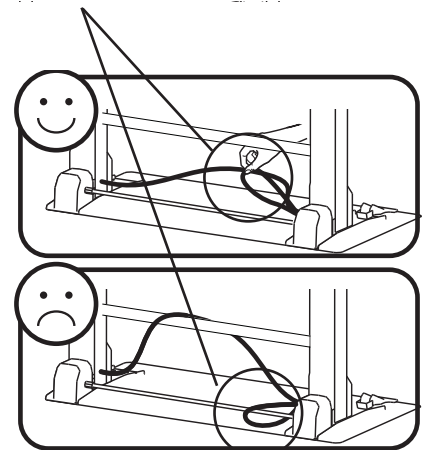

Set-up Steps

4 Set the left leg (without hand brake) upright on the worksurface. Attach the left end of the sync rod to the left leg. Make sure the brake cables don't loop around the sync rod. See Warning, right.

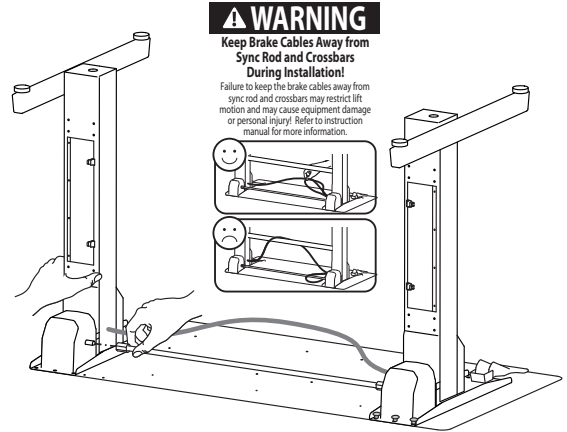

5 Partially insert 9 of the provided #12-14 wood screws in the left leg and worksurface.

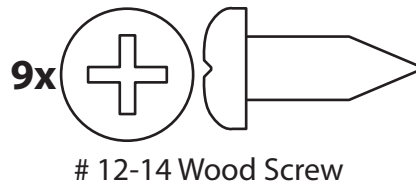
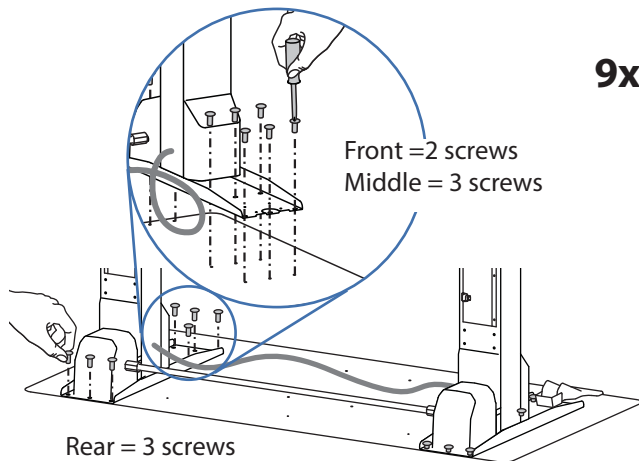

6 Use a Phillips screwdriver to insert the provided M5x6 mm screws into the two crossbars connecting the left and right legs. Make sure the brake cables don't loop around the crossbars.

Tighten the screws slightly one at a time and repeat to ensure that the tension on every screw is equal.



NOTE: Do not overtighten screws. overtightening screws may result in stripping the holes and may cause the installation to be unsafe.

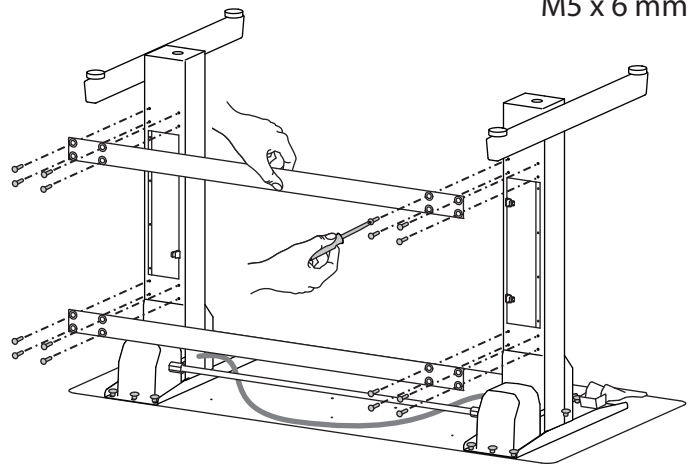
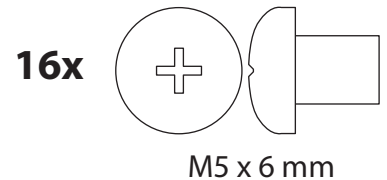

7 Use a Phillips screwdriver to tighten down the screws attaching the legs to the worksurface.



NOTE: Do not overtighten screws. overtightening screws may result in stripping the holes and may cause the installation to be unsafe.

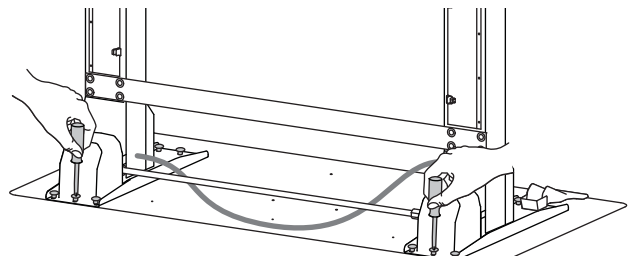

Set-up Steps

8 Capture the brake cable in the cable clip as illustrated, then use a Phillips screwdriver to attach the cable clips to bottom of work surface with the provided M2.9 x 8 mm screws.

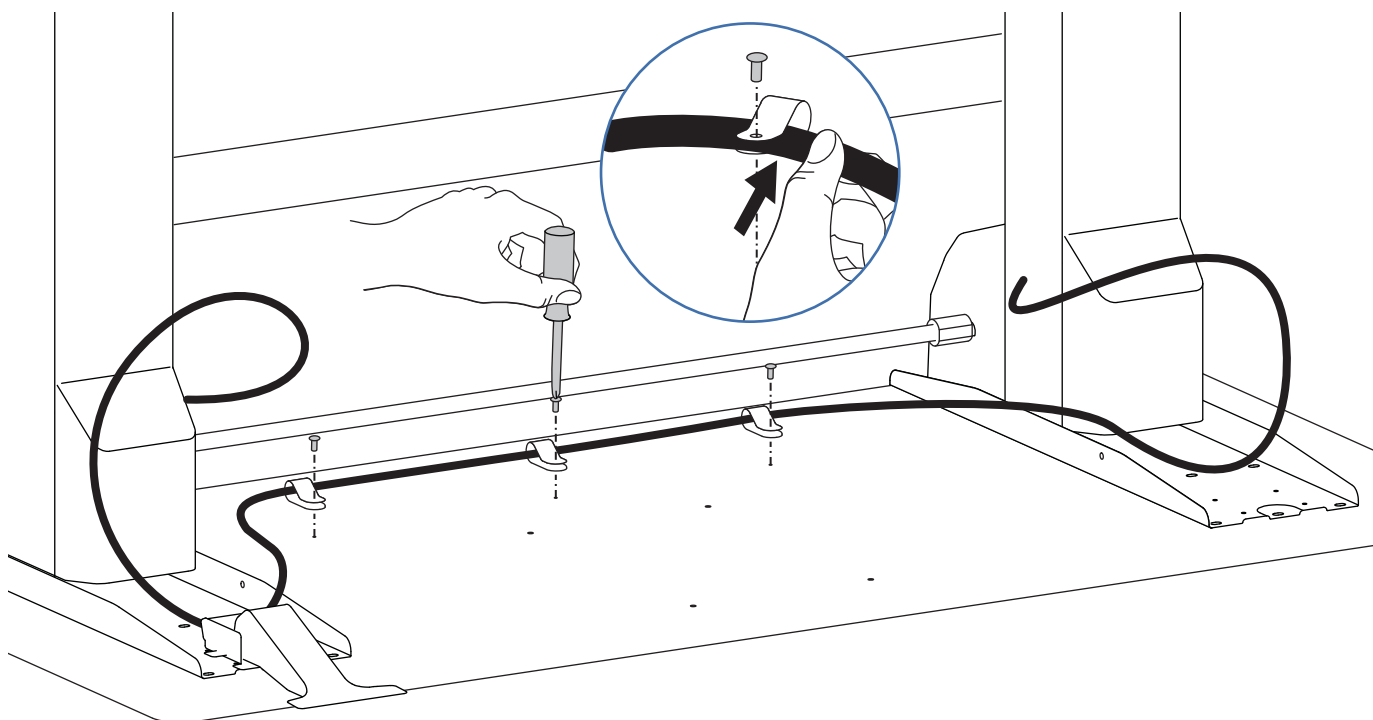

9 Using the 2 provided cable ties, attach brake cable to the legs leaving as much slack in cable as possible between the cable tie and the leg to allow desk top to raise up unrestricted.

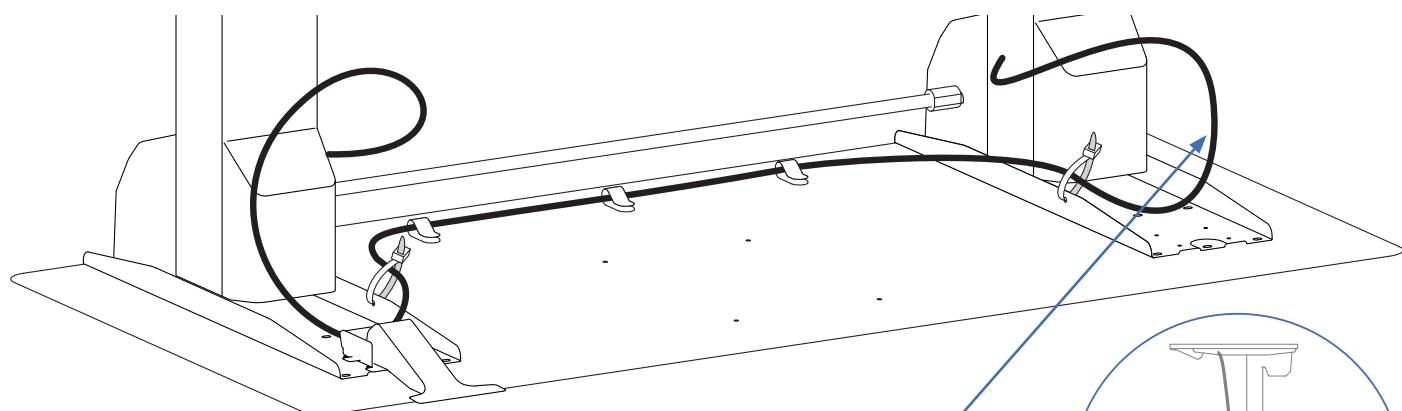
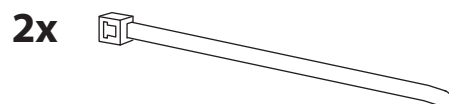

NOTE: Leave as much slack in cable as possible between the cable tie and the leg to allow desk top to raise up unrestricted. Failure to follow this may result in equipment damage.

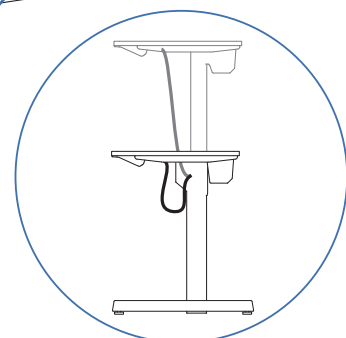

Set-up Steps

10 Set the desk upright onto its legs.

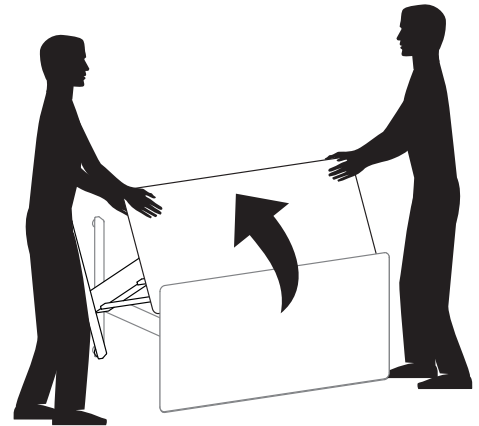
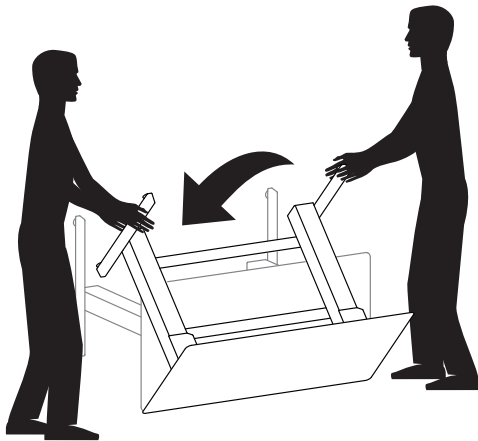

**CAUTION!
LIFT HAZARD!**

Two persons are required for this step. Failure to follow this warning may result in equipment damage and or personal injury.

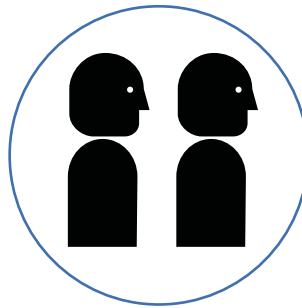

11 Adjust the riser on each leg and check with a level to make sure the work surface is even.

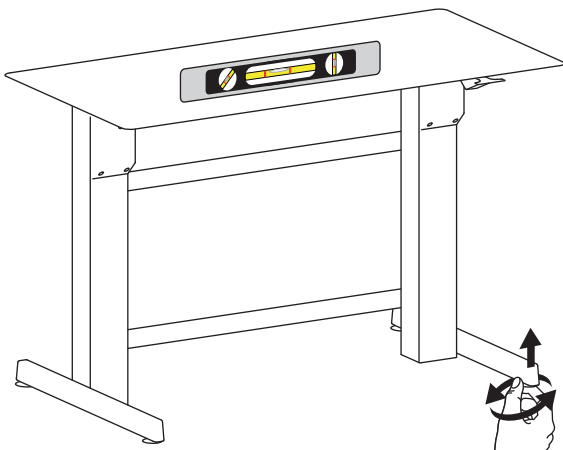

Spin Left to Raise.

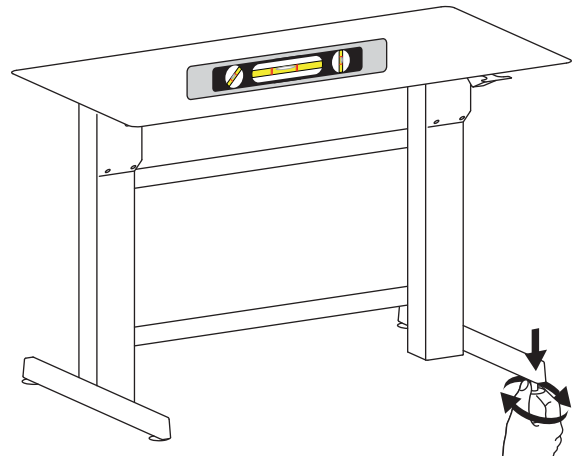

Spin Right to Lower.

Set-up Steps

12 Remove the 4 brake stop screws before installing equipment.

Remove the 2 stop screws from the legs then the 2 stop screws from the brake to allow the worksurface to raise and lower.

IMPORTANT!

Save these stop screws and instructions. Install stop screws when shipping or storing this product. Failure to follow these instructions may cause lift engine to expand rapidly and may result in equipment damage and or personal injury.

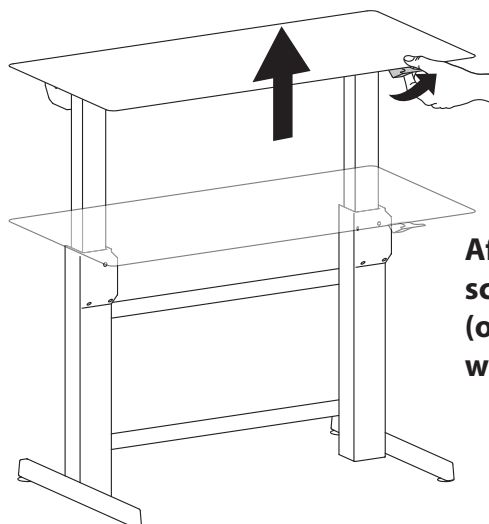
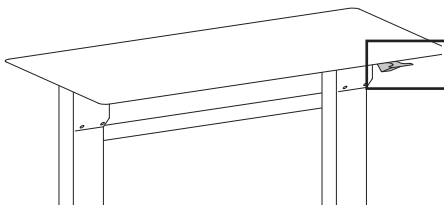
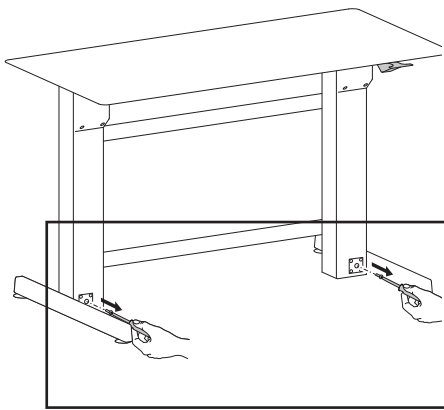
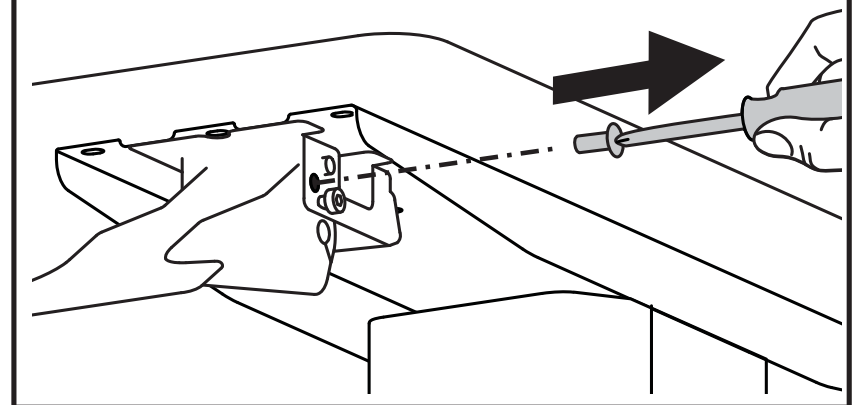
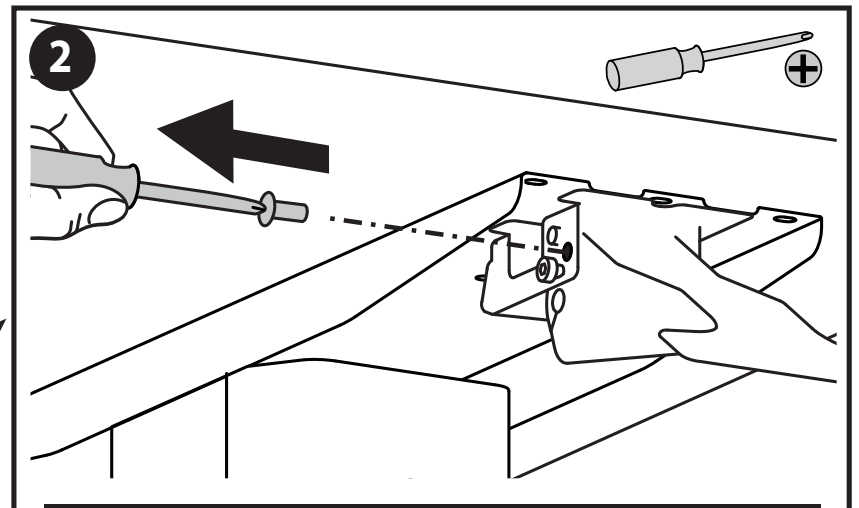
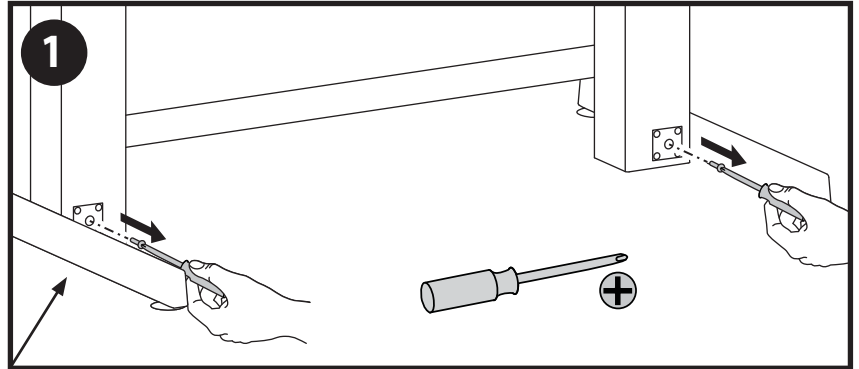

After you remove the 4 brake stop screws, release the hand brake (on the right leg) and move the worksurface up to highest level.

Set-up Steps

13 Install all equipment.



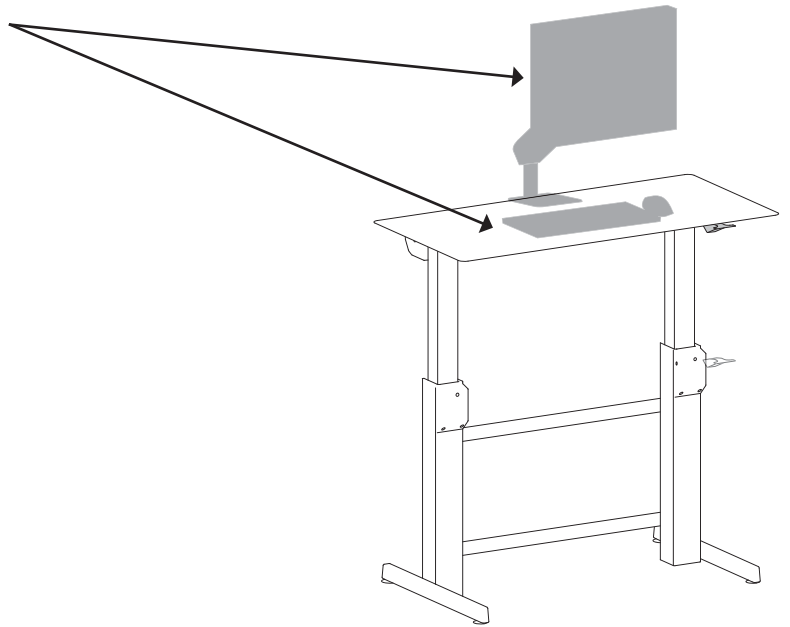

CAUTION! Make sure you leave 20" (508mm) of slack in all equipment cables to allow the worksurface to raise up it's full 20" (508mm). Failure to allow enough slack in equipment cables may cause cables to get pulled, equipment to fall off desk and may result in product damage and or personal injury.



14 Adjustment Step

IMPORTANT! This product will need tension adjustments once installation is complete. Make sure all equipment is properly installed on the product before attempting range of motion or tension adjustments. Any time equipment is added or changed on this product resulting in a different mounted weight, you should repeat the adjustment steps to ensure safe and optimum operation. This product should move smoothly and easily through the full range of motion. If movement is difficult follow the adjustment instructions to loosen or tighten the tension to create a smooth, easy motion. Depending on your product and the adjustment, it may take many turns to notice a difference.

WARNING
IMPACT HAZARD

Moving Parts Can Crush And Cut

Minimize Lift Strength BEFORE:
- Removing Mounted Equipment
and

Insert 4 Stop Screws BEFORE:
- Shipping or Storing (i.e. when Desk is not upright).

To Minimize Lift Strength
Refer to installation manual for instructions on how to minimize lift strength.

To Insert 4 Stop Screws
Refer to installation manual for instructions on installing stop screws.

Failure to heed this warning may result in serious personal injury or property damage!

For More information and instructions visit www.ergotron.com or contact Ergotron Customer Care at **1-800-888-8458**.
826-901-00

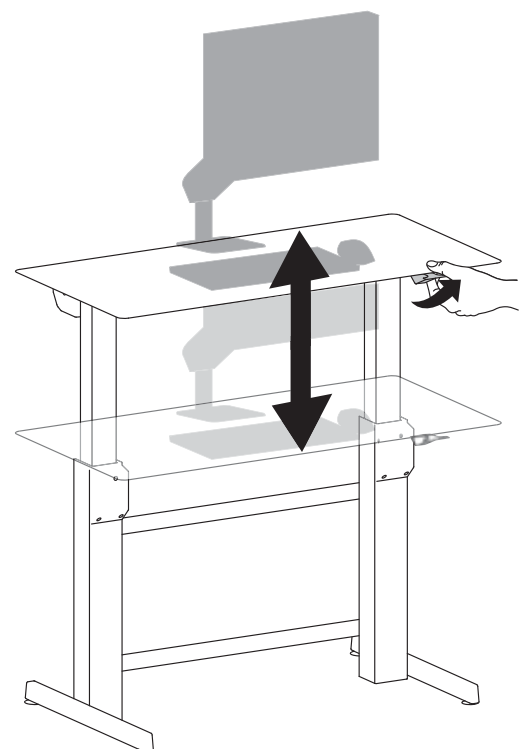

14 Adjustment Step

Release the hand brake (on the right leg) and move the worksurface up to highest level.

Push in the cover located behind each leg to access the adjustment point.



NOTE: The covers on the legs will not open unless the worksurface has been lifted to it's full height. The worksurface will not lower unless the covers have been completely closed.

Maintain equal amount of tension on both legs by alternating the tension adjustment from one leg to the other using a 14mm socket drill.

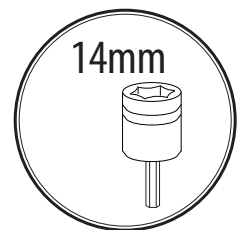
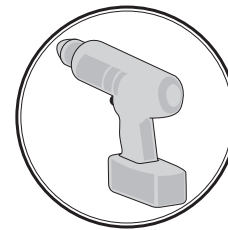
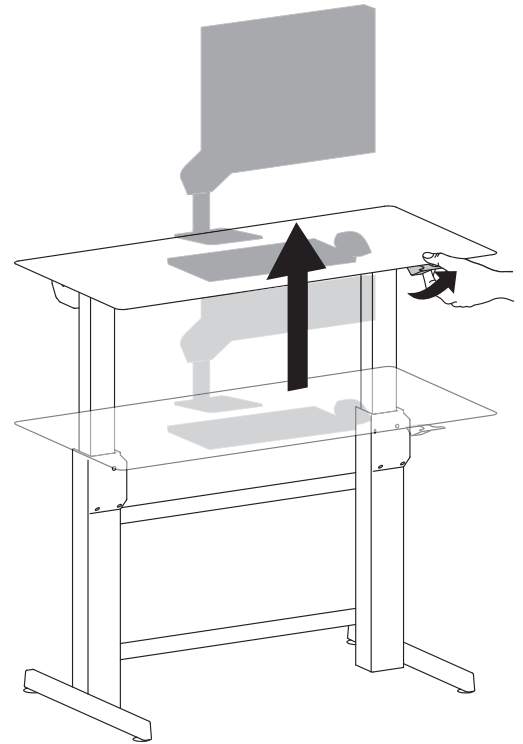

 Spin left to loosen tension (for lighter loads).

 Spin right to tighten tension (for heavier loads).

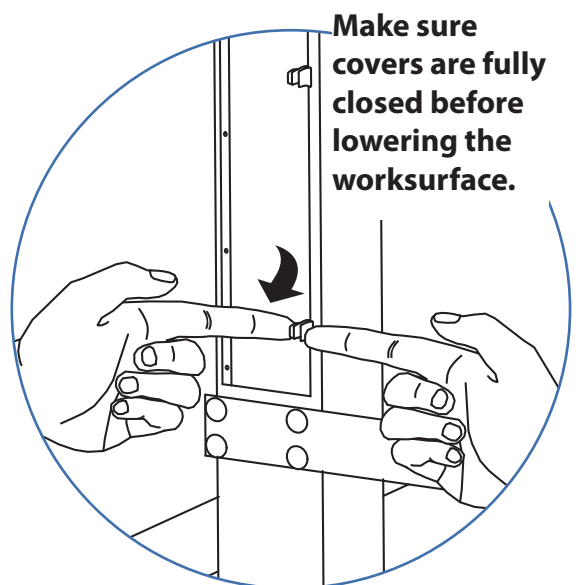
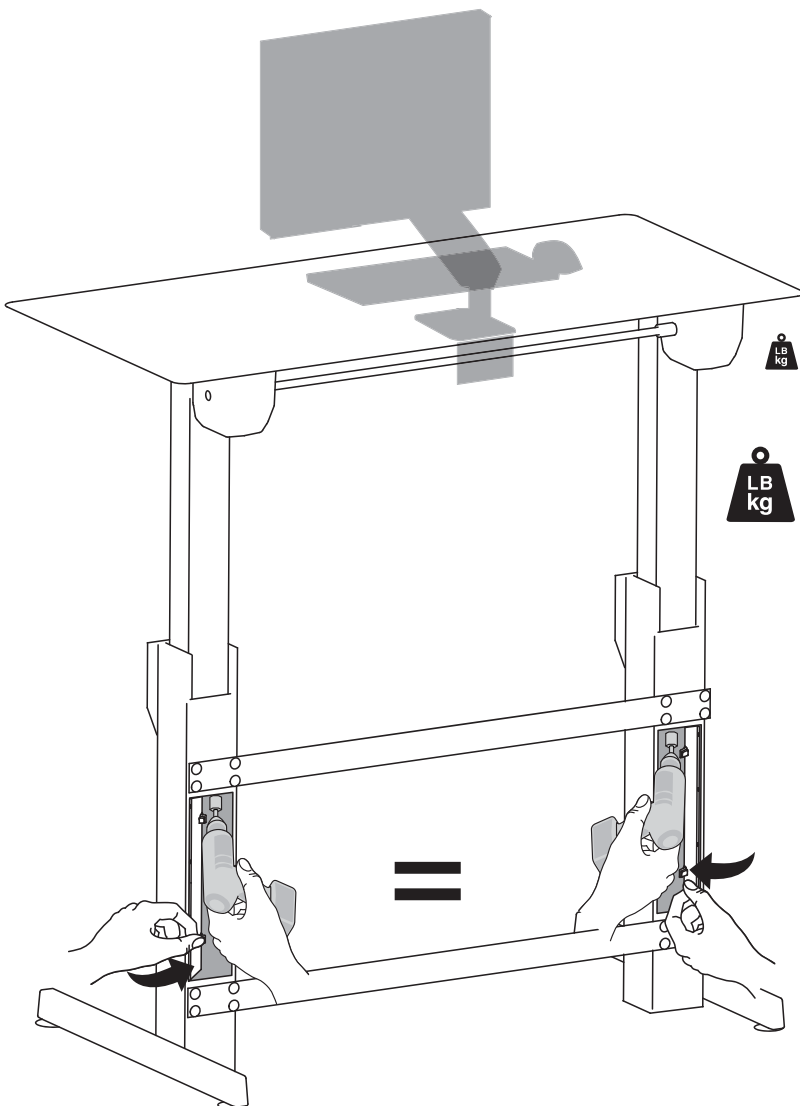

Make sure covers are fully closed before lowering the worksurface.



WARNING! DO NOT tip desk over to adjust. Only perform adjustment while desk is upright. Failure to follow these instructions may cause the lift engine to expand rapidly and may result in equipment damage and or personal injury.

APPENDIX A - Minimize Lift Tension



WARNING. Before removing mounted equipment (monitor, arm, stand CPU, etc.), from desk, or to prepare for shipping or storing the desk it is extremely important to minimize the lift tension. Failure to install these instructions may cause lift engine to expand rapidly and may result in equipment damage and or personal injury.

1. Release the hand brake (on the right leg) and move the worksurface up to highest level.
2. Push in the cover located behind each leg to access the adjustment point.



NOTE: The covers on the legs will not open unless the worksurface has been lifted to it's full height. The worksurface will not lower unless the covers have been completely closed.

3. To minimize tension, turn adjustment bolts left using a 14mm socket drill. Maintain equal tension on both legs by alternating adjustment from one leg to the other. Keep adjusting until the wrench stops turning.
4. Once at minimum tension it is ok to remove mounted equipment.

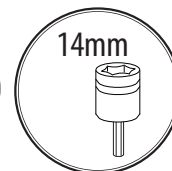
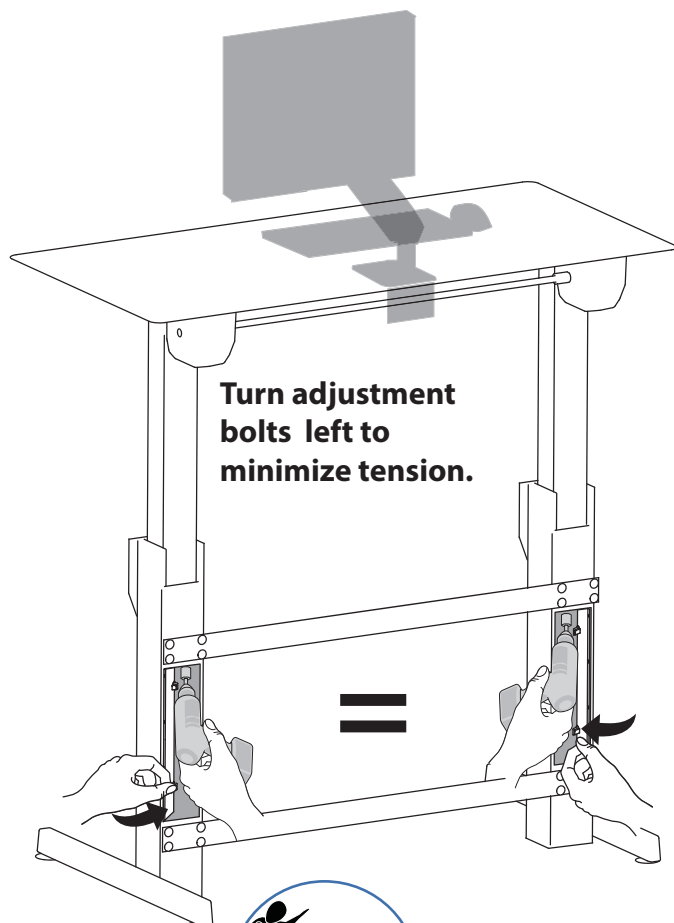
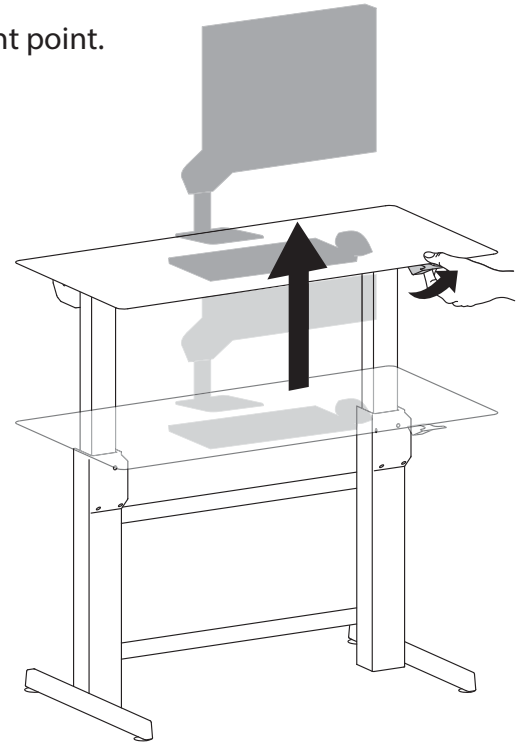

Make sure covers are fully closed before lowering the worksurface.

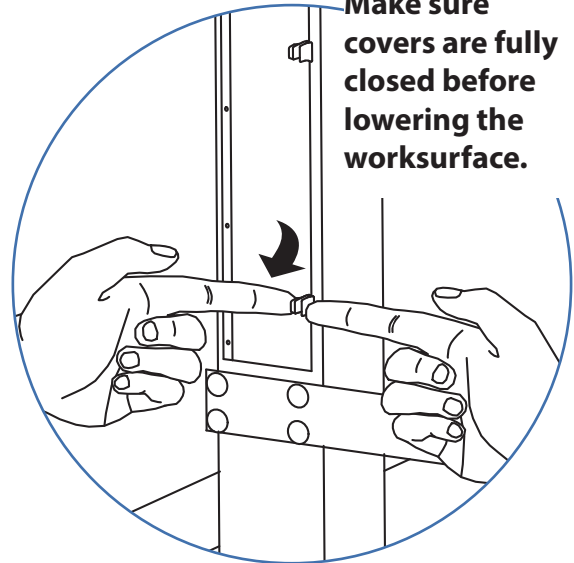

WARNING! DO NOT tip desk over to adjust. Only perform adjustment while desk is upright. Failure to follow these instructions may cause the lift engine to expand rapidly and may result in equipment damage and or personal injury.

APPENDIX B - Inserting Stop Screws



WARNING. Before shipping or storing the desk, or in cases where the desk is placed on its back or side*, it is extremely important that the 4 stop screws be re-inserted. Failure to follow these instructions may cause lift engine to expand rapidly and may result in equipment damage and or personal injury.

1. Follow instructions in Appendix A to minimize lift tension.
2. Push the desk down to its lowest position.
3. Insert 2 stop screws at the bottom of each leg.
4. Insert the other 2 stop screws on each side of the hand brake located on the right side of the worksurface.
5. Once the 4 stop screws have been installed the desk can be shipped or stored.

* Placing the desk on its back or side is not recommended.

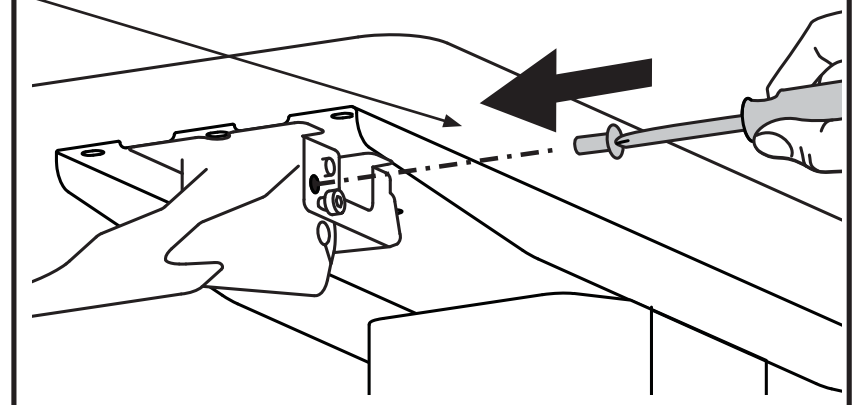
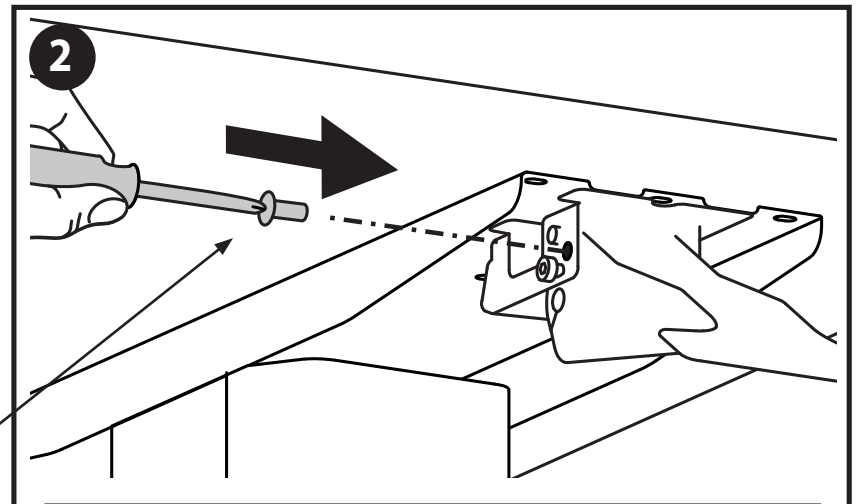
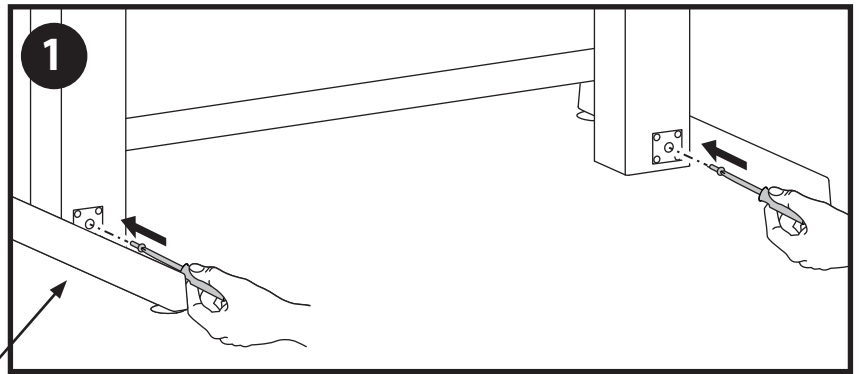
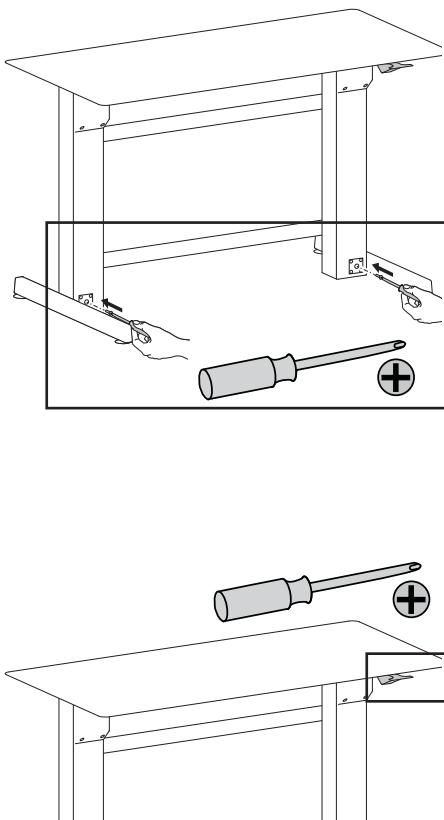

Set Your Workstation to Work For YOU!

Configure su estación de trabajo para que trabaje para USTED.

Ajustez votre station de travail en fonction de VOS besoins !

Richten Sie Ihren Arbeitsplatz so ein, dass er für SIE arbeitet!

Stel uw werkstation zo in dat het voor U werkt!

Approntare la stazione di lavoro nella posizione ergonomica ottimale.

一人ひとりにピッタリのワークステーション!

按照您自身的需要设置工作站!

Learn more about ergonomic computer use at:

Más información sobre el uso ergonómico de ordenadores:

Apprenez-en plus sur l'utilisation ergonomique d'un ordinateur sur :

Weitere Informationen zur ergonomischen Computernutzung finden Sie unter:

Leer meer over ergonomisch computergebruik op:

Per ulteriori informazioni sull'uso ergonomico del computer:

人間工学的なコンピュータの使用法については次のサイトを参照してください
想进一步了解以符合人体工程学的方式使用计算机的知识，请访问：

www.computingcomfort.org

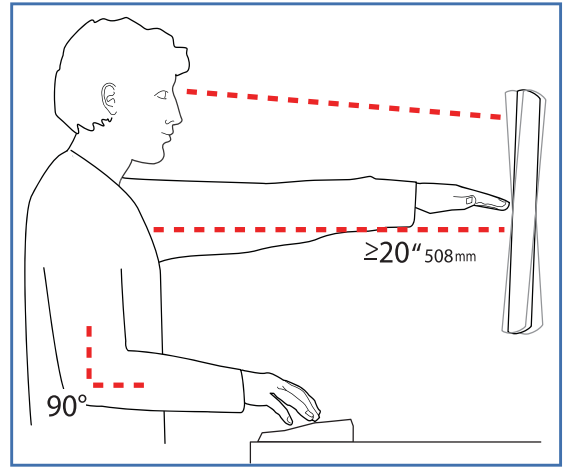

To Reduce Fatigue

Breathe - Breathe deeply through your nose.

Blink - Blink often to avoid dry eyes.

Break - 2 to 3 minutes every 20 minutes

• 15 to 20 minutes every 2 hours.

- Height** Position top of screen slightly below eye level.
Position keyboard at about elbow height with wrists flat.
- Distance** Position screen an arm's length from face—at least 20" (508mm).
Position keyboard close enough to create a 90° angle in elbow.
- Angle** Tilt screen to eliminate glare.
Tilt the keyboard back 10° so that your wrists remain flat.

- Altura** Coloque el borde superior de la pantalla ligeramente por debajo de la altura de sus ojos.
Coloque el teclado aproximadamente a la altura de los codos con las muñecas planas.
- Distancia** Coloque la pantalla a una distancia de un brazo desde la cara, esto es, unos 50 cm (20 pulgadas).
Coloque el teclado lo suficientemente cerca para que el codo forme un ángulo de 90°.
- Ángulo** Inclíne la pantalla para eliminar los reflejos.
Inclíne el teclado 10° hacia atrás para que las muñecas sigan en posición plana.

- Para reducir la fatiga**
Respirar - Respire hondo por la nariz.
Parpadear - Parpadee a menudo para que no se sequen los ojos.
Descansar • 2 o 3 minutos cada 20 minutos
• 15 o 20 minutos cada 2 horas.

- Hauteur** Positionnez l'écran du haut légèrement en dessous du niveau du regard.
Positionnez le clavier à peu près à la même hauteur que vos coudes, pour que vos poignets soient à plat.
- Distance** Positionnez l'écran à un bras de distance de votre visage, à au moins 508 mm (20 pouces).
Positionnez le clavier assez près pour que vos coudes forment un angle de 90°.
- Angle** Inclinez l'écran pour ne pas être ébloui.
Inclinez le clavier vers l'arrière de 10° pour que vos poignets soient à plat.

- Pour réduire la fatigue**
Respirer - Respirez profondément par votre nez.
Clignez des yeux - Clignez souvent des yeux pour ne pas avoir les yeux secs.
Faites des pauses • 2 à 3 minutes toutes les 20 minutes
• 15 à 20 minutes toutes les 2 heures.

- Höhe** Positionieren Sie die obere Kante des Bildschirms knapp unter Augenhöhe.
Positionieren Sie die Tastatur bei flach aufgelegten Handgelenken auf Ellenbogenhöhe.
- Abstand** Positionieren Sie den Bildschirm mindestens eine Armlänge (50 cm) von Ihrem Gesicht entfernt.
Positionieren Sie die Tastatur nahe genug, um einen Ellenbogenwinkel von 90° zu ermöglichen.
- Winkel** Neigen Sie den Bildschirm so, dass ein Spiegeleffekt vermieden wird.
Neigen Sie die Tastatur um 10° nach hinten, sodass Ihre Handgelenke flach aufliegen.

- Vermeiden von Ermüdungserscheinungen**
Atmen - Atmen Sie tief durch die Nase ein und aus.
Blinzeln - Blinzeln Sie so oft wie möglich, um trockene Augen zu vermeiden.
Pausen • Machen Sie alle 20 Minuten eine Pause von 2-3 Minuten
• Machen Sie alle 2 Stunden eine Pause von 15-20 Minuten.

- Hoogte** Zet de bovenkant van het scherm iets boven ooghoogte.
Plaats het toetsenbord op ongeveer ellebooghoogte met de polsen plat.
- Afstand** Plaats het scherm op een armlengte van uw gezicht — op ten minste 508 mm (20 in).
Zet uw toetsenbord zo dichtbij dat u een hoek van 90° in de ellebogen hebt.
- Hoek** Kantel het scherm om weerspiegeling te elimineren.
Kantel het toetsenbord 10° naar achteren, zodat uw polsen plat blijven liggen.

- Om vermoeidheid te verminderen**
Ademen - Adem diep door uw neus in en uit.
Knipperen - Knipper regelmatig om droge ogen te vermijden.
Pauses nemen • 2 tot 3 minuten elke 20 minuten
• 15 tot 20 minuten elke 2 uur.

- Altezza** Posizionare la parte superiore dello schermo leggermente sotto il livello degli occhi.
Posizionare la tastiera circa all'altezza dei gomiti, in modo che i polsi siano piatti.
- Distanza** Posizionare lo schermo a un braccio di distanza dal viso, almeno a 20" (508 mm) di distanza.
Posizionare la tastiera affinché sia abbastanza vicina da costringere i gomiti a un angolo di 90°.
- Angolazione** Inclinare lo schermo in modo da eliminare i riflessi.
Inclinare la tastiera indietro di 10° in modo che i polsi rimangano piatti.

- Per ridurre l'affaticamento**
Respirazione - Respirare profondamente dal naso.
Battito delle palpebre - Battete spesso le palpebre per evitare che gli occhi si asciughino.
Pause • Fare una pausa di 2 - 3 minuti ogni 20 minuti
• Fare una pausa di 15 - 20 minuti ogni 2 ore.

- 高さ** スクリーンの上端が目よりわずかに下に来るようにします。
キーボードが、手首を水平に伸ばした状態でひじとほぼ同じ高さに来るようにします。
- 距離** スクリーンを顔から腕の長さ分（少なくとも508mm）離します。
ひじが直角になる位置にキーボードを置きます。
- 角度** 反射光をなくすようにスクリーンの角度を調整します。
キーボードを後方に10°傾けて、手首が水平になるようにします。

- 疲れを軽減する方法**
呼吸 - 鼻から深く呼吸します。
まばたき - 目の乾燥を防ぐために頻繁にまばたきしてください。
休憩 • 20分ごとに2~3分
• 2時間ごとに15~20分

- 高度** 屏幕顶端的位置要稍低于视线高度。
将键盘放置在大约肘部的高度并且手腕要能放平。
- 距离** 将屏幕摆放在距离面部一臂长的位置——至少 508mm (20")。
键盘的位置要够近，以使肘部形成直角。
- 角度** 倾斜屏幕以消除眩光。
将键盘向后倾斜 10 度，使手腕能保持放平。

- 为了减轻疲劳**
呼吸 - 通过鼻子深呼吸。
眨眼 - 经常眨眼可避免眼睛干涩。
休息 • 每隔 20 分钟休息 2 至 3 分钟
• 每隔 2 小时休息 15 至 20 分钟。

ERGOTRON®

While Ergotron, Inc. makes every effort to provide accurate and complete information on the installation and use of its products, it will not be held liable for any editorial errors or omissions (including those made in the process of translation from English to another language), or for incidental, special or consequential damages of any nature resulting from furnishing this instruction and performance of equipment in connection with this instruction. Ergotron, Inc. reserves the right to make changes in the product design and/or product documentation without notification to its users. For the most current product information, or to know if this document is available in languages other than those herein, please contact Ergotron. No part of this publication may be reproduced, stored in a retrieval system, or transmitted in any form or by any means, electronic, mechanical, photocopying, recording or otherwise without the prior written consent of Ergotron, Inc., 1181 Trapp Road, Eagan, Minnesota, 55121, USA. Patents Pending and Patented U.S. & Foreign. Ergotron is a registered trademark of Ergotron, Inc.

Americas Sales and Corporate Headquarters

St. Paul, MN USA
(800) 888-8458
+1-651-681-7600
www.ergotron.com
sales@ergotron.com

EMEA Sales

Amersfoort, The Netherlands
+31 33 45 45 600
www.ergotron.com
info.eu@ergotron.com

APAC Sales

Tokyo, Japan
www.ergotron.com
apacustomerservice@ergotron.com

Worldwide OEM Sales

www.ergotron.com
info.oem@ergotron.com