

DM-MD8X1-4K-C/HD-MD8X1-4K 4K Scaling Presentation Switchers

DO Install the Device

The DM-MD8X1-4K-C and HD-MD8X1-4K can be mounted into a rack, mounted under a table, or placed onto a flat surface.

Mounting into a Rack

The DM-MD8X1-4K-C and HD-MD8X1-4K each occupy 1U of rack space. Using a #1 or #2 Phillips screwdriver, attach the two included rack ears to the device. Then, mount the device into the rack using four mounting screws (not included). Refer to illustration ❶.

❶ Mounting into a Rack

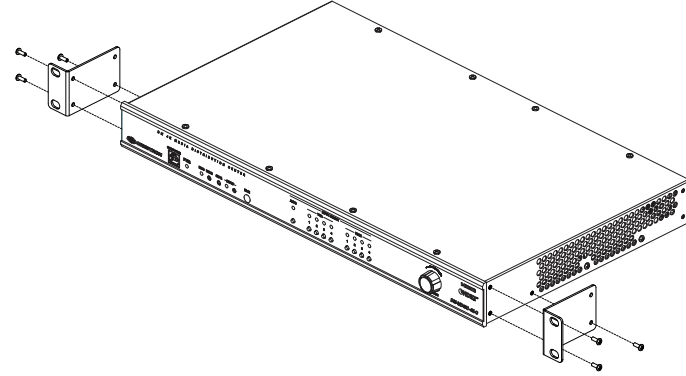

Mounting under a Table

Using a #1 or #2 Phillips screwdriver, attach the four included table mount brackets to the device. Then, attach the four table mount brackets to the underside of the table using four mounting screws (not included). Refer to illustration ❷.

❷ Mounting under a Table

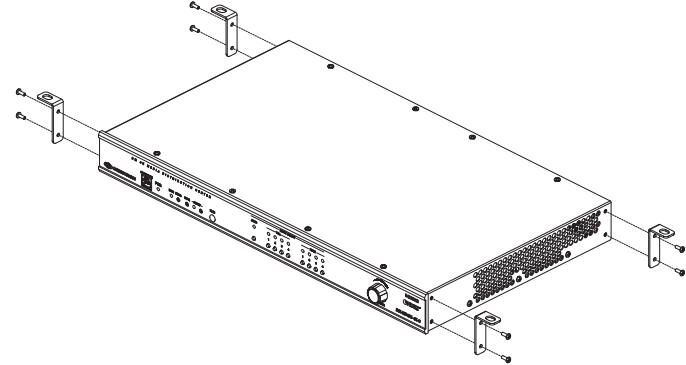

Placing onto a Flat Surface

When placing the device onto a flat surface or stacking it with other equipment, attach the included feet near the corners on the underside of the device.

DO Check the Box

QUANTITY	PRODUCT	COLOR	PART NUMBER
2	Bracket, Rack Ear, 1U		2032122
4	Bracket, Under Table Mount		2041951
2	Connector, 5-Pin		2003577
1	Emitter Probe, IR, Crestron® STIRP		2001137
4	Foot, 0.5" x 0.5" x 0.23", Adhesive	Black	2002389
1	Power Cord, 6' 7" (2 m)		2001134
DM-MD8X1-4K-C Only			
1	Connector, 3-Pin		2003575

Not Included: Cables, Rack Mount Screws, and Table Mount Screws

DO Make Connections to the Rear Panel

Make connections to the rear panel of the device. For DM-MD8X1-4K-C rear panel connections, refer to illustration ❸. For HD-MD8X1-4K rear panel connections, refer to illustration ❹.

❸ DM-MD8X1-4K-C Rear Panel Connections

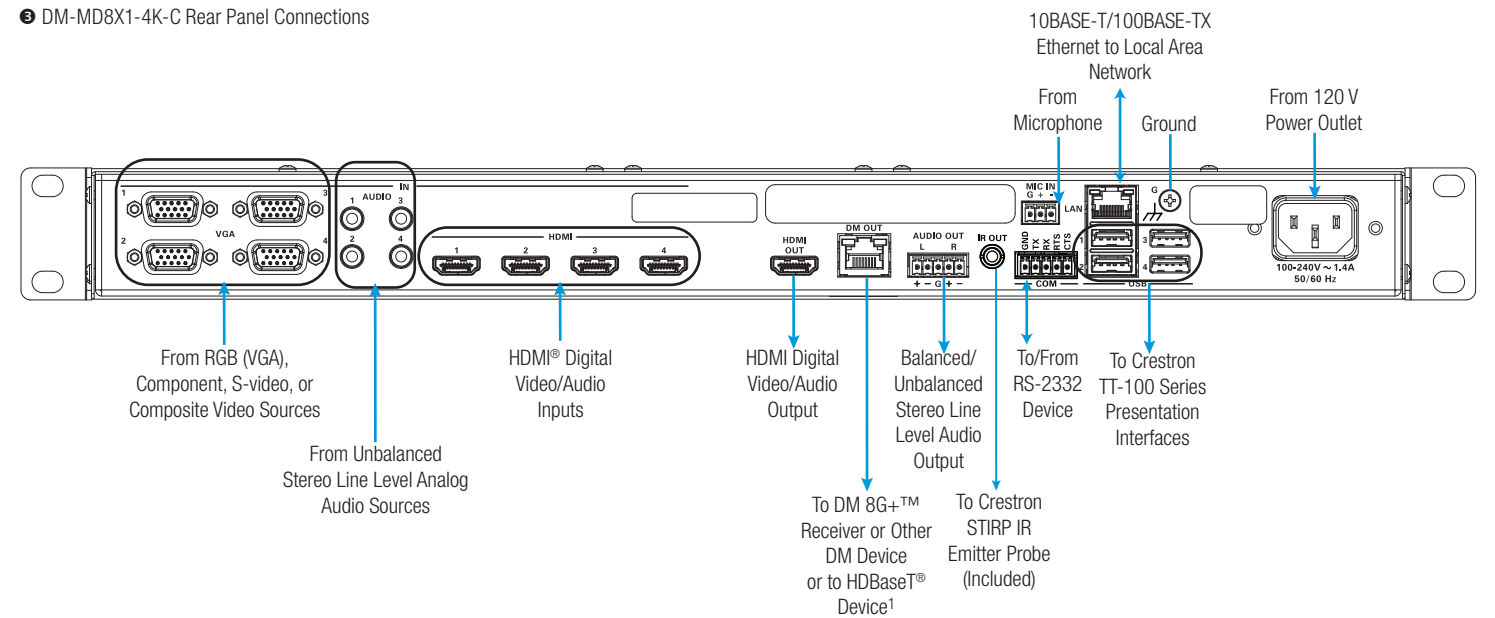

❹ HD-MD8X1-4K Rear Panel Connections

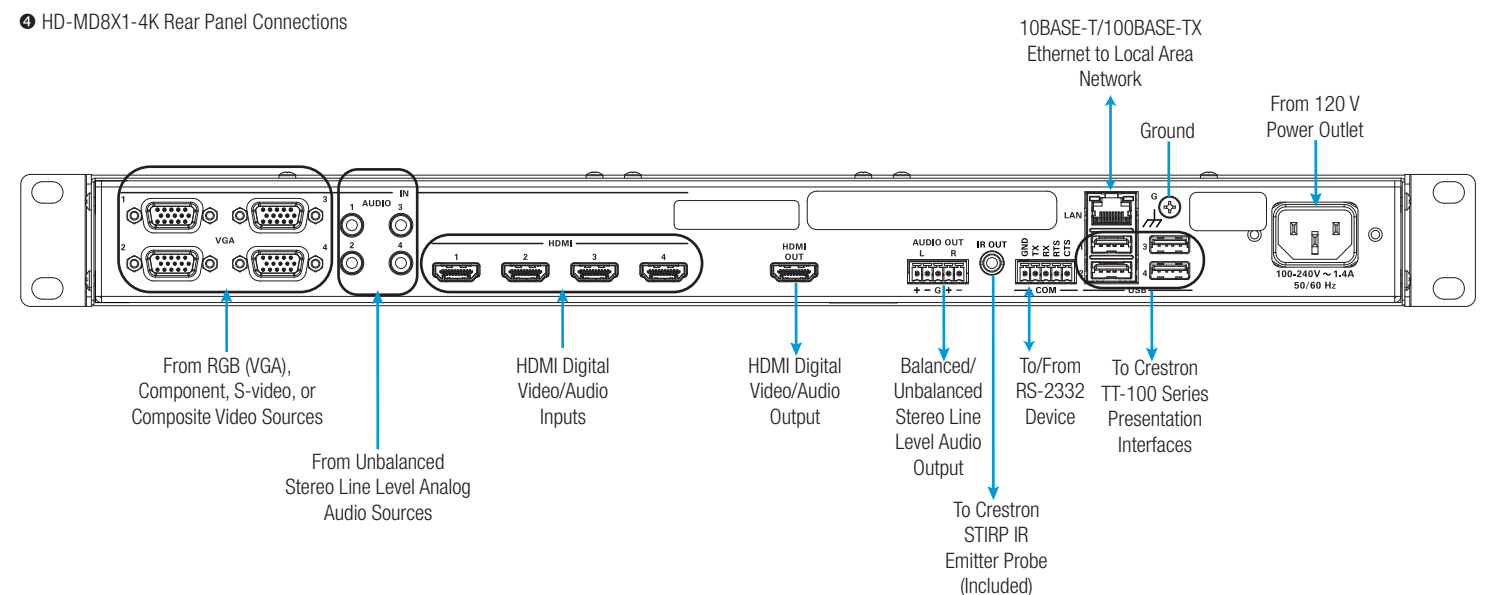

DO Determine the Address of the Device

The DM-MD8X1-4K-C and HD-MD8X1-4K can be addressed using the hostname. The default hostname of the DM-MD8X1-4K-C is DM-MD8-xxxxxxx and the default hostname of the HD-MD8X1-4K is HD-MD8-xxxxxxx, where xxxxxxxx consists of the last eight characters of the MAC address. For example, if the MAC address of the DM-MD8X1-4K-C is 00:10:7F:08:09:AA:05, the default host name is DM-MD8-0809AA05. The MAC address is labeled on the rear panel of the DM-MD8X1-4K-C and HD-MD8X1-4K.

Alternatively, the DM-MD8X1-4K-C and HD-MD8X1-4K can be addressed using the IP address. By default, DHCP is enabled. To set a static IP address, use Crestron Toolbox™ on a PC that connects to the device via the Ethernet network or a USB connection to the COMPUTER port on the front panel of the device. If the PC connects to the Ethernet network, the Device Discovery Tool in Crestron Toolbox can be used to find the current IP address.

DO Commission the System

Using the web interface, configure the DM-MD8X1-4K-C or HD-MD8X1-4K. To access the web interface, open a web browser and go to the setup directory of the device by entering either of the following:

`hostname/setup` (*hostname* is the hostname of the device)

or

`xxx.xxx.xxx.xxx/setup` (*xxx.xxx.xxx.xxx* is the IP address of the device)

The DM-MD8X1-4K-C and HD-MD8X1-4K also provide the built-in DMPS .AV Framework™ Base Program that enables complete system control without requiring additional programming. Control is accomplished using the Crestron TSW-752 Touch Screen (TSW-752-B-T DMPS3 PAK KIT), the Crestron XPanel interface, or the Crestron Control App for Apple® iPad®. All VT Pro-e® projects are available on the DM-MD8X1-4K-C and HD-MD8X1-4K product web pages. For more information, refer to the DMPS .AV Framework Base Software Operations Guide (Doc. 7646) at www.crestron.com/manuals.

DO Allow Automatic Switching or Manually Select an Input

By default, automatic switching of inputs is enabled. Automatic switching causes the last connected input to be routed to the output. The AUTO LED lights to indicate that automatic switching is enabled.

To manually select and activate the desired input, press one of the **VGA** (1–4) or **HDMI** (1–4) **INPUT SELECT** buttons. Refer to the following table for a summary of the LED behavior of selected and nonselected inputs.

COLOR	DESCRIPTION
Solid green	The input is the active selection, and an incoming signal is detected.
Flashing green	The input is the active selection, and an incoming signal is not detected.
Solid amber	The input is not the active selection, and an incoming signal is detected.
Off	The input is not the active selection, and an incoming signal is not detected.

NOTE: Manual selection of an input disables automatic switching. When automatic switching is disabled, the AUTO LED turns off.

1. The DM OUT port of the DM-MD8X1-4K-C is a PoDM (Power over DM) and PoH (Power over HDBaseT) PSE (Power Sourcing Equipment) port. Any wiring that is connected to a PoDM or PoH PSE port is for intra-building use only and should not be connected to a line that runs outside of the building in which the PSE is located.

DM-MD8X1-4K-C



HD-MD8X1-4K





DO Learn More

Visit the website for additional information and the latest firmware updates.

Crestron Electronics

15 Volvo Drive, Rockleigh, NJ 07647
888.CRESTRON | www.crestron.com

 As of the date of manufacture, the product has been tested and found to comply with specifications for CE marking.

 This product is Listed to applicable UL Standards and requirements by Underwriters Laboratories Inc.

Federal Communications Commission (FCC) Compliance Statement

This device complies with part 15 of the FCC Rules. Operation is subject to the following two conditions:

(1) This device may not cause harmful interference, and (2) this device must accept any interference received, including interference that may cause undesired operation.

Caution: Changes or modifications not expressly approved by the manufacturer responsible for compliance could void the user's authority to operate the equipment.

Note: This equipment has been tested and found to comply with the limits for a Class B digital device, pursuant to part 15 of the FCC Rules. These limits are designed to provide reasonable protection against harmful interference in a residential installation. This equipment generates, uses and can radiate radio frequency energy and, if not installed and used in accordance with the instructions, may cause harmful interference to radio communications. However, there is no guarantee that interference will not occur in a particular installation.

If this equipment does cause harmful interference to radio or television reception, which can be determined by turning the equipment off and on, the user is encouraged to try to correct the interference by one or more of the following measures:

- Reorient or relocate the receiving antenna
- Increase the separation between the equipment and receiver
- Connect the equipment into an outlet on a circuit different from that to which the receiver is connected
- Consult the dealer or an experienced radio/TV technician for help

Industry Canada (IC) Compliance Statement

CAN ICES-3(B)/NMB-3(B)

Rack Mounting Safety Precautions

- **Elevated Operating Ambient Temperature:** If installed in a closed or multi-unit rack assembly, the operating ambient temperature of the rack environment may be greater than room ambient temperature. Therefore, consideration should be given to installing the equipment in an environment compatible with the maximum ambient temperature (T_{ma}) specified by the manufacturer.
- **Reduced Airflow:** Installation of the equipment in a rack should be such that the amount of airflow required for safe operation of the equipment is not compromised.
- **Mechanical Loading:** Mounting of the equipment in the rack should be such that a hazardous condition is not achieved due to uneven mechanical loading.
- **Circuit Overloading:** Consideration should be given to the connection of the equipment to the supply circuit and the effect that overloading of the circuits might have on overcurrent protection and supply wiring. Appropriate consideration of equipment nameplate ratings should be used when addressing this concern.
- **Reliable Earthing:** Reliable earthing of rack-mounted equipment should be maintained. Particular attention should be given to supply connections other than direct connections to the branch circuit (e.g., use of power strips).

The specific patents that cover Crestron products are listed at patents.crestron.com.

The product warranty can be found at www.crestron.com/warranty.

Crestron, the Crestron logo, .AV Framework, Crestron Toolbox, DM 8G+, and VT Pro-e are either trademarks or registered trademarks of Crestron Electronics, Inc. in the United States and/or other countries. Apple and iPad are either trademarks or registered trademarks of Apple Inc. in the United States and/or other countries. HDBaseT and the HDBaseT Alliance logo are either trademarks or registered trademarks of the HDBaseT Alliance in the United States and/or other countries. HDMI and the HDMI logo are either trademarks or registered trademarks of HDMI Licensing LLC in the United States and/or other countries. Other trademarks, registered trademarks, and trade names may be used in this document to refer to either the entities claiming the marks and names or their products. Crestron disclaims any proprietary interest in the marks and names of others. Crestron is not responsible for errors in typography or photography.

This document was written by the Technical Publications department at Crestron.

©2015 Crestron Electronics, Inc.